

METHODS AND TECHNIQUES OF CONTINUOUS MEASUREMENT OF WATER QUALITY IN RIVERS, EFFLUENTS AND PURIFICATION PLANTS

W. HUSMANN

Ahornzweig 1, 43 Essen-Stadtwald, W. Germany

ABSTRACT

The continuous measurement of substances in water is of increasing significance in the economics of water quality. As a result of continuous measurement, sewage clarification can be automatically controlled with the aid of suitable equipment. Considering the increasing development of automatic appliances for the control of water as well as sewage cleaning, we shall in future have to study intensively the problems of data transmission, data transmission collation and data transmission processing in order to evaluate and transform such data into decisive aid. Only thus can the greatest benefit be obtained for the economics of water quality with these latest developments in measuring techniques, the latter being described on various reliably working appliances.

The belief that measurement means knowledge, and that automatic measurement and control installations bring about savings in costs, has become general in all modern industrial and production plants. Even if effluents, and the corresponding plants for purification, are not productive because they cost money under any conditions and do not give a profit, recent decades have shown very conclusively that treatment plants for waste water may be better controlled by the installation of automatic measurement and control devices, and that often substantial savings in production costs may be obtained when the measurements are correctly interpreted and used. In this connection, I may mention the neutralization plants or the addition and content of oxygen in activated sludge plants.

As in every technical process, it is urgently required in the supervision of industrial effluents and in the operation of purification plants to compensate the shortage and increasing cost of labour by automatic devices, and, on the other hand, to carry out many time-consuming individual measurements and operations in the purification plant with the help of reliable measuring and control units. Continuous supervision of industrial effluents by recording instruments of all kinds is of considerable importance in many aspects. No industrial plant should be indifferent when the effluent

carries away saleable products such as solids from a paper or cardboard mill, coal sludge from a coal washing plant, acids or alkaline solutions from the respective plants, because of tube leakage, carelessness of the operators, or any other reason.

In the purification plants of municipal authorities and industries, continuous supervision of the effluent intake is important in order to protect the installations from damage.

The protection of sewers, and even more of the river, against aggressive waste water also demands continuous and recorded supervision. It will not be news to you when I point out that unfortunately up to the present, especially at night or on holidays, unwelcome waste waters are emitted which might destroy concrete canals, interrupt the operation of a purification plant, or kill the fish in the river. It is difficult to discover the culprit when there is no continuous and recorded supervision.

The rapid progress of the economy with its diversity of new products—for example the plastics or detergent industry—has in recent decades continually created new problems of treatment and purification of widely varying effluents for all countries in their effort to protect and preserve the supply of surface and underground water for drinking and industrial use. It is generally known that an increasing share of the demand for water by man and by industry has to be met by the use of surface water. The technique of measurement and control in the treatment of effluents plays a decisive part in the effort to preserve our water reserves for these purposes. The application of suitable and modern measuring and recording techniques to detect significant contents in waters or effluents is a prerequisite for the preservation of water which is so important to our life.

For many years experts and companies working in this field have undertaken in all countries the development and construction of suitable apparatus. In Germany, a committee on measurement and control instruments was founded a few years ago with the assistance of the government departments concerned. This committee aims, to promote, by information exchange and research, the development and construction of measuring and control instruments for the supervision of rivers and purification plants, and to keep the experts informed on the present state of measurement and control techniques. It is planned to promote contacts with foreign agencies and research institutions. The specialized task of this committee besides the exchange of information, consists of a general survey of present-day possibilities for measurement, and of situation analysis to show which apparatus for measurement and control is necessary to cope with the tasks which have to be met today and in the future. The publication 'Deutsche Dokumentationszentrale Wasser' has already contained relevant articles in several issues.

SAMPLING TECHNIQUES

Let me now first say something about sampling and flow measurements in water.

The purpose of sampling is to take from the water or effluent to be investigated a fraction which is representative and in sufficient quantity for exami-

METHODS OF CONTINUOUS MEASUREMENT OF WATER QUALITY

nation and characterization. To get representative samples from the water to be characterized, the sampling method has to suit the problem of the examination. Furthermore, the following requirements must be met :

(a) The composition of the water at the point of sampling must be representative of the total amount of water or of the cross-section of flow in a river.

(b) The composition of the sample taken must be a representative average for a fixed time interval.

(c) The sampling technique must guarantee that the water sample taken is not changed by the process of sampling.

(d) The sample taken should not change up to the moment of analysis for the contents and properties to be examined.

(e) The sample taken must be protected by appropriate measures from changes in the contents and properties which are to be examined. During sampling, a deposition of matter, the decomposition of organic substances by bacteria, or the introduction of substances from the material of the sampling device which might influence the results, must be avoided.

(f) To protect the samples from change during storage or transport, the metabolism of micro-organisms must be stopped or retarded. Possible measures are, e.g. storage in the dark, addition of acid or alkali, conservation by chemical additives, cooling or freezing.

The following kinds of samples may be discerned :

(a) *Individual sample*

The individual sample is a sample taken at a fixed time from a fixed spot.

(b) *Local average sample*

The local average sample is a mixture of samples taken from different places in a body of water or in a flow cross-section.

(c) *Time average sample*

The time average sample is a sample taken continuously or discontinuously during a fixed time interval.

If the contents and the properties of the water or effluent do not show any variations with time and locality in the body of water or in the flow cross-section, the conditions will be sufficiently well represented by an individual sample.

If the composition of the water shows local variations in the body of water or in the flow cross-section to be investigated, samples must be taken from several places. Representative averages may be obtained by calculation from the samples taken from the different places, taking into account the relative amount of water in each sample, or by making up a local average sample.

Changes with time in the water must be found in a representative way and by a succession of individual samples. If variations of concentration with time and fluctuations of the flow occur in a river, continuous sampling with a constant sample volume will result in a time average sample having the average concentration of the material contained in the water during the sampling interval (the simple arithmetic mean of the concentrations).

If a flow-proportional sample is taken (that means the amount of water taken out is directly proportional to the amount of water passing at the same time), the result is a time average sample with the weighted concen-

tration of the material contained in the total mass of water which has passed during the time the sample was taken, i.e. one obtains a weighted arithmetic mean of the concentrations.

Flow-proportional sampling is necessary to ascertain the amount of the freight, that is the amount of substance transported in the flowing water. Values from a time average sample taken discontinuously are the more representative the more individual samples are taken and the slower the changes in the water and the fluctuations of the flow.

The design of devices for the continuous or discontinuous sampling of the water of effluent which is to be investigated, and for the transport to the sample containers is governed by the following conditions: quality of the water to be examined; fluctuations in the water flow and the surface level; special conditions at the point of sampling; possibility of electric power supply for the instruments; object of the investigation.

The sampling devices should be designed in such a way that checks for proper functioning and current maintenance may be carried out easily and reliably. The individual parts allow easy reassembling when demanded by changing requirements, and an exchange of complete units in case of failure. All the parts exposed to the water or effluent must be made of corrosion-resistant material. To protect the sampling devices from clogging or damage, bulky material such as rags, fibres, wood chips etc. must be prevented from entering the sampling devices.

Conveyors have to transfer the water to be investigated to the sample containers. Pumps or bucket elevator devices may be used for this purpose. Conveying devices may be omitted when a difference in levels is available or when sampling is carried out from a pipe under pressure.

Pumps must be sturdy and reliable in operation. They may not have submerged valves, particularly when samples are taken from waste water, since these valves will be prevented from proper functioning by sediments and corrosion after a short time of operation.

The amount of water delivered should, if possible, be independent of the pressure head, in order to convey a constant amount despite fluctuations in the water head and partial clogging of the tubing, thereby simplifying the proportioning of the samples.

Piston and membrane pumps delivers a constant amount of water even with a varying pressure head. These are designed with small dimensions when used as sampling pumps, and the ball or disc valves which they commonly contain are liable to be troublesome in operation, so that the pumps are only suitable for conveying water or effluent free from bulky suspensions.

Screw conveyor pumps are self-priming. The amount delivered is nearly independent of the pressure head. Dry running for an extended time must be avoided. It is possible to convey water with a high fraction of impurities but without hard or granular material.

Centrifugal pumps. The delivery of these pumps depends on the pressure head. Centrifugal pumps of small capacity, which may be used for sampling devices, are not very suitable for pumping waste water which contains bulky suspensions.

Peristaltic pumps make use of a travelling narrow zone of compression of special elastic tubing, generating, at the same time, suction in the preceding

part of the tubing and drawing in more water or effluent. When the tubing is totally compressed the pump is self-priming and the amount delivered is independent of the pressure head. Bulky impurities, however, may present difficulties during operation. If the water or effluent to be delivered contains hard or granular solid particles such as sand or particles of coal, the peristaltic pump is subject to excessive wear.

Flow-proportional sampling may be carried out in a simple way from a calibrated channel using a multi-channel peristaltic pump, i.e. a peristaltic pump with several lines of tubing. The intake points of the individual lines are adjusted in height in such a way that the delivery of a flow-proportional amount of water is guaranteed.

Vibrating hose pumps consist of two joined lengths of tubing, one of which is coupled to a vibrating system supplied with alternating current, while the other has a kind of flap valve. The first section is compressed periodically. On compression, the liquid inside the tubing moves away towards both ends, while its streams back on dilatation. The operation of the flap valve decreases the amount of liquid streaming back from one end so that a directional flow is effected.

The pump operated below water level, is sturdy and resistant to corrosion. Dry running is not harmful to it and the conveyance of water or effluent with suspended solids is feasible.

Compressed air pumps. The compressed air needed for the operation of these pumps may be supplied directly from compressors or taken out of central systems or cylinders. Water samples delivered by compressed air pumps are not suitable for the determination of dissolved gases like oxygen or carbon dioxide.

Compressed air lifts. In this device, a submerged tank fills with water while the air emerges at the same time. By the action of compressed air, the content of the tank is then delivered partially or completely, dependent on the individual design. The amount delivered is independent of the pressure head or surface level provided the available air pressure is sufficient and the tank is completely submerged while filling. According to their design, these pumps require one or several valves which should be suitably arranged out of contact with the water or effluent. The conveyance of unpurified effluent or other water carrying suspensions is possible by suitable designing.

Mammoth pumps. These compressed air pumps have no valves or moving parts. Therefore, they are fundamentally appropriate for the conveyance of severely contaminated water or effluent. However, when used as sampling pumps their small dimensions may lead to clogging. Their use is normally restricted to considerable depths of water. The amount delivered is dependent on the pressure head. The volume of air required is a function of the amount of water to be delivered, of the height of lift, and especially of the ratio of lift height to depth of immersion.

Suction lifts. The water or effluent to be investigated is sucked into the sampling container by a vacuum. The amount is dependent on the pressure head.

Electrical energy is not required in most cases. One employs either evacuated vessels or generates a vacuum during the sampling process. Water running out of a Mariotte suction bottle generates reduced pressure in the

sampling container so that the liquid to be sampled is sucked into the sample collector.

When sampling is carried out continuously for extended periods, very small rates of flow will often result, so that matter in suspension is not with certainty included in the sample. The suction lift devices are employed preferable when the contents of the effluent are mostly in solution, or when a determination of the suspended matter may be omitted. Samples taken with suction lifts are not suitable for the determination of dissolved gases.

Occasionally, *bucket elevators* may be used for continuous sampling. Cups fastened to a travelling chain or held by rotating arms, discs or wheels take the samples from the water to be examined and convey them to a sample container. With sufficient capacity of the cups, suspended solids in water or effluent are also included with adequate accuracy.

Flow-proportional sampling is possible by controlling the speed of rotation, making it proportional to the flow of water which is measured concurrently.

In the same way, bucket elevators with sampling vessels which are shaped to conform with the flow curve of an open conduit take samples whose amount is proportional to the flow. When the device is installed in the conduit, special attention has to be paid to securing the precise level. For a flow-proportional delivery, the variations in the head of water may not exceed the maximum depth of filling.

Bucket elevators may be operated from the mains or from batteries. The flowing water may also supply the driving force. As already mentioned, paddles or waterwheels with the sampling cups fastened to them are used in this case.

To obtain time average samples, metering of the water or effluent taken out by the sampling device is necessary in cases where the amount of water delivered by the conveying device is neither constant with time nor proportional to the flow of water, or when the amount of water or effluent delivered exceeds the volume of the sample container.

With continuous sampling, a large quantity of water results because taking samples from water containing solids which may settle, or suspensions, requires high rates of flow and cross-section in closed systems for conveying the water samples. The sample volume which is limited for various reasons, as of transport and cooling of the samples, is therefore often exceeded. In this case the water is delivered continuously, but fed to the sample container only during brief intervals. When the amount delivered is neither constant nor proportional to flow, proportioning is governed by the feed period to the sample container. When the delivered amount is neither constant nor proportional to flow, calibrated vessels have to be used for metering.

When samples are taken from effluent free of biologically degradable substances and bulky suspended material, no special conditions have to be met with regard to the velocity of flow and to the cross-section in the conveying system when operation is either continuous or discontinuous. In such cases a separate metering device is rarely necessary.

Let me now say a few words on the metering devices. A proportioning device used for constant or flow-proportional delivery is shown in *Figure 1*.

METHODS OF CONTINUOUS MEASUREMENT OF WATER QUALITY

This proportioning instrument is designed after the principle of the shunt. The water or effluent delivered continuously flows through a movable pipe which can be brought into either of two positions by the action of an electromagnet. If no current flows in the magnetic coils, the tube is held

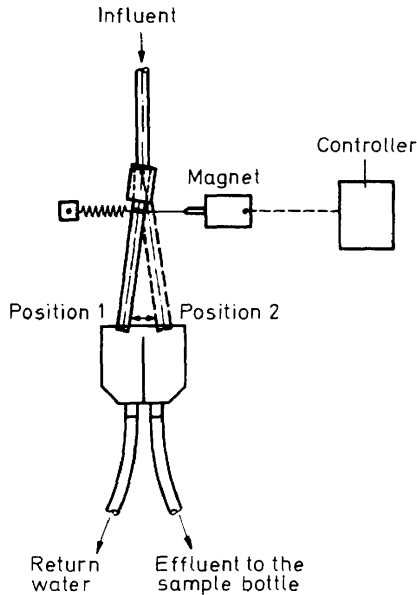

Figure 1. Proportioning device used for constant or flow-proportional delivery.

by a spring in position 1, and the water returns to the drain or to the river. With current flowing, the magnet switches the tube to position 2. The water delivery is then introduced into the sample container. After the current is shut off the tube returns to position 1.

The proportioning of samples by discontinuous introduction of the continuously delivered water or effluent into the sample container may also be carried out with the help of valves. However, valves are less safe in operation when used for water contaminated with solids.

Frequency and duration of the individual metering actions may be varied at will with the help of control devices so that any sample volume may be set in advance. By controlling either the frequency or the duration of the individual metering action depending on the flow of water, a flow-proportional, time average sample is obtained.

The instrument shown in *Figure 2* represents a proportioning device used for variable and flow-independent delivery. It consists essentially of two magnet valves and a measuring cup. Its operation may be described as follows.

After the entrance valve is closed the predetermined amount adjusts itself in the measuring cup. Shortly after this, the exit valve is opened and the contents of the measuring cup run into the sample container. After the

exit valve is closed again and the entrance valve has been opened, the system is one more filled with water. By varying the volume of the cup, and the interval between the individual metering actions, the sample volume may be varied within wide limits. With suspensions of bulky material the use of magnet valves may cause difficulties in operation.

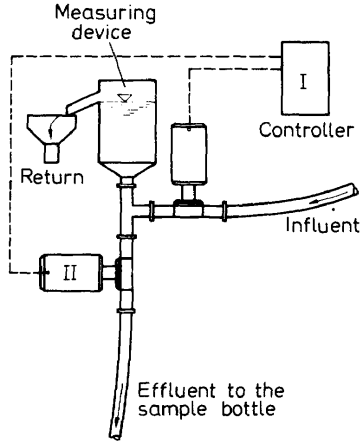

Figure 2. Proportioning device used for variable and flow-independent delivery.

If the samples in an examination of water or effluent are to be collected for certain time intervals in successively different vessels, the so-called sample distribution devices are required. In order to use these distributors in a number of ways they should be able to take twelve or more samples in succession.

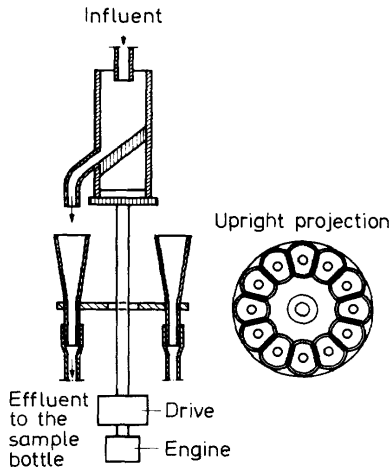

Figure 3. Distribution apparatus.

METHODS OF CONTINUOUS MEASUREMENT OF WATER QUALITY

Frequently the distribution of samples is done by means of the so-called distributor disc. In the instrument shown in *Figure 3*, the funnels arranged in a circle are filled from a rotating feed tube. The ports of the funnels discharge into the sample containers. It is possible to use a different design in which the sample containers are charged directly. The containers are then arranged in a circle. The samples are then distributed either by a rotating feed tube, or the containers pass the fixed feeder tube in a circular movement.

Frequently a so-called distributor carriage is used. The sample containers are arranged in line on a carriage. For the distribution of the samples, the carriage moves forward to the next container after a fixed time interval. Special control devices acting on the distributor disc or distributor carriage allow any constant feed interval, or a series of different intervals, to be set in advance.

A well-known apparatus for sample distribution is shown in *Figure 4*.

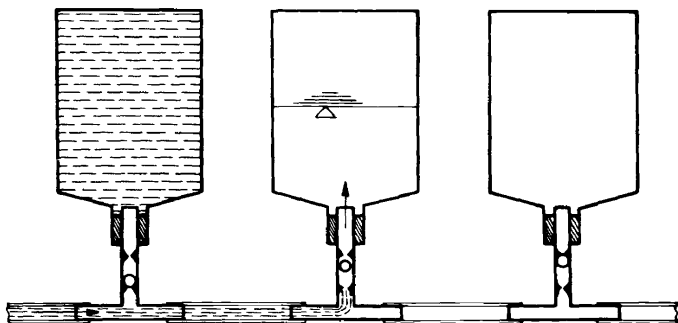

Figure 4. Apparatus for sample distribution.

The outstanding feature of this device is a specially designed tee-shaped tube which contains a floating ball valve in its vertical limb. The tees are joined to the top of a corresponding number of flasks and are interconnected. When one of the flasks has been filled, the floating ball is raised and pressed against the glass rim on the inside of the vertical limb of the tee, thereby closing the sample flask. The sampling intervals are given by the volume of the flask and the velocity of flow. The practical usefulness of this simple device is, however, limited since flow-proportional sampling is not possible, and since clogging cannot be avoided in the case of water or effluent carrying coarser dirt particles.

Finally, let me say something about the connecting tubes used in sampling apparatus. Plastic tubing has proved by experience to be the most useful connection between the individual parts of a sampling device. Other connections, such as glass or metal tubes, are applied only in special cases. The material of the plastic tubing should be flexible and resistant to wear and corrosion. To avoid a growth of algae in the connecting tubes, no transparent material may be used. The material should also not contaminate the flowing water with substances which might influence the results of the investigation.

When samples are taken from water or effluent which contains biologically degradable material, the velocity of flow in the tubes should not be lower than 1 m/s so that the unavoidable growth of fungi and algae may be reliably and continuously washed out of the tubing. The drag force resulting from this velocity should prevent clogging or sedimentation even with waters containing bulky and heavy material.

With decreasing diameter of the connectors the danger of clogging is enhanced. As a result of general experience, a minimum diameter of not less than 5 mm in the connecting tubes should be used. Connections with diameters of 8–12 mm have been shown to function reliably in practice. The amount of water flowing is then in the range of 200–400 l per hour with a velocity of 1 m/s.

When water or effluent which does not contain any organic, degradable material or bulky suspension is sampled, however, there is more freedom of choice in the velocity of flow and the cross-section.

INSTRUMENTS FOR MEASURING THE WATER FLOW

Instruments for measuring the water flow in open channels or in tubes operate on different principles. They have to conform to the following requirements: sufficient accuracy under any conditions of flow and drainage; small loss of pressure head; wide range of measurement; reliability in operation and long service intervals.

Let us turn first to the instruments for flow measurement in open channels with a free water surface. To begin with the Venturi flume has to be considered. Flow measurements in strongly polluted water or effluent are possible reliably and with sufficient accuracy, easy maintenance and a small loss in head.

Venturi flumes are designed in such a way that, at the point of minimum width, the state of the fluid changes from flowing to surging. This makes it possible to deduce the flow of water from a knowledge of the head water level alone. In the entrance of purification plants, or in the drains from chemical industries or metallurgical plants with their large volume of water or effluent, Venturi measurements may be successfully applied.

The flow of water may also be determined by a calibrated weir. A prerequisite for measurements with a calibrated weir is a freespilling overflow. The amount of water or effluent passing is determined from the water head upstream of the weir. The measurements may be disturbed by sediments in front of the weir which may build up because of the small velocities of flow, thus impairing the conditions assumed in the calculation. Furthermore, fibrous material tends to cling to the crest of the weir and may alter the cross-section of the passage. Accurate continuous measurements are, therefore, possible only in water or effluent which is free of easily settling or fibrous material.

The flow of water in pressurized tube ducts may be determined by means of throttles. A reduction in the cross-section of a tube containing a streaming medium causes an increase in the velocity of flow at the constriction. The pressure drop across the constriction is called the velocity head and is a direct measure of the flow. Throttle designs for the determination of the effective head are Venturi tubes, orifice plates or flow nozzles.

METHODS OF CONTINUOUS MEASUREMENT OF WATER QUALITY

For measuring and recording the effective kpressure, differential manometers or ring balances are in use. It is possible to incorporate a volume integrator and remote transmission of the results.

Inductive flowmeters may be used in pressure ducts for the measurement of water or effluent flow. The principle is based on Faraday's law of induction. A homogeneous magnetic field is built up in the tube perpendicular to the direction of flow. If the flowing water or effluent is electrically conducting, a voltage is induced perpendicular to the flow and to the magnetic field. It is proportional to the mean velocity and is therefore a linear measure of the flow. This voltage is detected by two electrodes let into the wall of the measuring tube and recorded in terms of flow rate by an instrument. Inductive flowmeters are sensitive to liquids contaminated with bulky material. The accuracy of flow measurements with the inductive method is about $\pm 1-2\%$ of the maximum flow rate. A prerequisite for accurate measurements is, however, that the electrical conductivity of the water or effluent should exceed a definite minimum value, and that the measuring tube should be completely filled with liquid.

It is also possible to carry out measurements of effluent flow in canals, open conduits, brooks and rivers with impeller wheels of the Woltman design or with water gauges having a clockwork means for automatically recording the variation in surface level. If the cross-section filled at a given surface level is known, the flow of water may be calculated or directly found from tables calculated for any given surface level.

Let me now say something about present-day, modern possibilities of measuring flow rate. Because of their outstanding properties, radioisotopes have in the last few years found increasing application in the investigation of complex processes in vastly different fields of science and technology. They have also turned out to be a valuable help in hydrometry and hydraulics and have opened the way to new methods of measurement and investigation. The great corporations for water economy in the Ruhr area, the Emscher-genossenschaft, Lippeverband and Ruhrverband, to mention just a few examples have used radioactive substances since 1950 to determine times of passage or of residence in mechanical or biological purification plants, and the measurement of passage times and flow velocities in rivers.

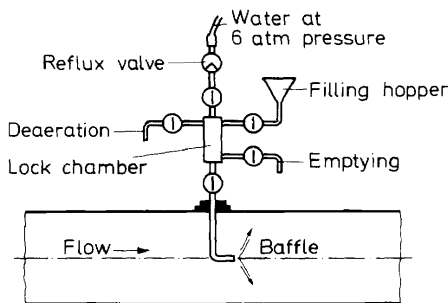

Figure 5. Injection of radioactive solution into a pressurized tube.

To find the pump efficiency in water or effluent pumping stations, the flow rate in the adjoining pressure ducts was determined by means of radioisotopes. In this method, a small amount of radioactive solution is introduced into the tube duct at a point selected at will. *Figure 5* shows schematically the device used to inject a radioactive solution into a pressurized tube. The injector tube, with its exit formed into an orifice, is situated in the centre of the tube cross-section. A conical baffle arranged just opposite to the orifice effects an immediate and fairly homogeneous distribution of the injected solution over the cross-section of the tube.

The flow rate of the injected cloud is determined, by using Geiger counters, from the time of passage (T) of the cloud between two probes located downstream at a suitable distance from the point of injection. From T and from the volume (V) of the tube between these points, the amount of water passing per second is given as

$$Q = \frac{V}{T}$$

This procedure is identical with Allen's well-known method of measuring the velocity of flow by means of a salt solution, with the exception that a radioactive solution is introduced instead of a salt solution, and that, instead of the change in electrical conductivity of the flowing water, the change in radioactivity is detected. In these measurements, the artificial radioisotope Br^{82} was used as an indicator. It has a half-life of 36 hours and is soluble in water in the form of NH_4Br . When radioactive bromine is used, it is sufficient to use 0.5–1 mC in 50 cm^3 of water which is introduced into the tube duct by the injector described above. For four experiments, not more than 1 g of radioactive NH_4Br was required.

While salt solutions may give rise to changes in water density when used in velocity measurements and thus affect the flow conditions, a radioactive solution has no influence whatever on the flow process.

The use of isotopes is also important if one has to find the velocity of flow of sewage plant sludges in the pressure lines. When operating sludge pressure tubes it is frequently of interest to know the capacity of pumps or compressors required when the sludge has to be transferred across a distance of several kilometres to a sludge drying bed or a dump, and its viscosity is known to have a definite value. In a few control experiments at the Ruhrverband, an underground sludge tube was dug up in several places, and the passage of a small rubber sponge previously dipped in a radioactive solution was detected. The method using small pieces of sponge was selected in order to give only a brief pulse in the Geiger counter, so that the flow velocity could be measured exactly. The experiments confirmed the accuracy of the flow velocity calculated as a function of the viscosity of the sludge.

The brief explanations given above show that valuable information on passage times in tube lines may be gathered with the help of radioactive isotopes.

For the cleaning effect of a purification plant, the residence time of the waste water in the different stations of the plant is of decisive importance.

It is well known that mechanical purification of waste waters is carried out by the slow passage of the waste water across large basins, while suspensions and sediments collect at the bottom of the basins. The measure-

ment of the sedimentation time, which is important for the effect of clarification, is hardly possible by the usual means. Colour solutions cannot be detected in the contaminated water after a short time, or are more or less absorbed by the sludge.

Salt additions, which allow the flow velocity to be determined from the progress of dilution, are of little use when the original content of salts in the waste water is already high. The flow of water in the sedimentation tanks is too slow for velocity measurements with impeller wheels.

By an addition of radioactive bromine to the entry of the clarifying basin, and measurements of the radioactivity in the outlet with specially constructed counter tubes, the time of residence may be directly ascertained from the flow rate function. The Geiger tubes used in these measurements had a length of 1 m; they were built at the central workshop at the Max-Planck-Institut at Göttingen. An instrument made by Friesecke und Höpfner at Erlangen was used as counting register.

In the same way as in the sedimentation tanks of the mechanical effluent treatment, radioisotopes may find applications in the measurement of residence times of waste water in biological purification plants such as percolating filters or activated sludge plants.

The flow velocity of a river is an essential for a great number of measurements and computations in water economy, in particular in waste water technology. The self-cleaning capacity is strongly dependent on the flow velocity of a river, besides many other factors. It is also important to know the velocity of an influx of waste running down a river, and the extent of mixing with the river water. Depending on conditions and possibilities, the passage time in a river has been measured with floats, dyes or salt solutions up to now.

Measurement with floats, designed as surface or rod floats, is the most simple procedure. It has, however, a number of drawbacks and is not very reliable. For example, the velocity of the float is dependent on its position in the cross-section of the drain. The surface float may have a velocity different from that of the rod float which has a greater depth of immersion, and in particular its velocity and direction may be strongly affected by wind. When the flow velocity is measured by means of salt solutions, a very concentrated salt solution is added abruptly and the dissipation time is measured by the electrical conductivity. A prerequisite for the application of this method is the constancy of the intrinsic salt content, so that the conductivity of the river water should remain constant during the measurements. This necessary condition is not fulfilled in waters which are intermittently charged with salt-containing effluent. With continuous and strong fluctuations of the salt content, that means of the electrical conductivity, it is therefore impossible to measure the time of flow by addition of salt solutions in a satisfactory manner.

Determinations of flow times of waters by means of dyes require photometric measurements to give results of tolerable accuracy. Fluorescein or uranine yellow are frequently used as dye substances. Very often the determination of the colour intensity at the individual measuring points in a water has to be carried out with appropriate instrumentation in the laboratory after taking the water samples, and may be very time-consuming.

After corresponding trial runs, the flow time of the Emscher, a tributary of the Rhine with a run of 80 km, was measured by means of radioactive isotopes in 1950.

Figure 6 shows the general arrangement, the points of addition and of detection for measurements with radioactive material along the Emscher.

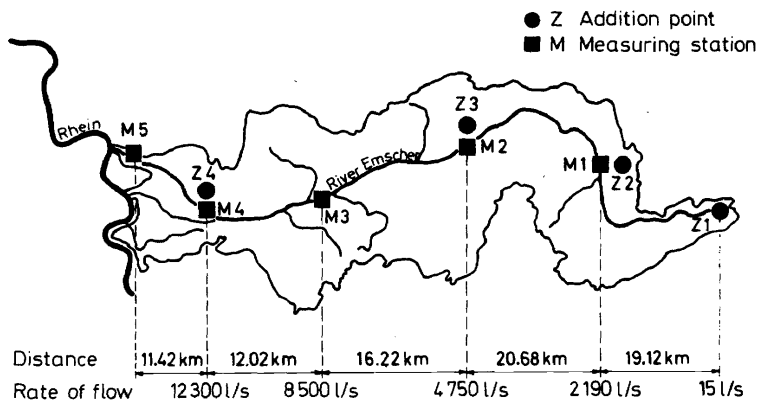

Figure 6. Measurements made along the river Emscher with radioactive substances.

The bromine isotope Br^{82} , mentioned previously, was used and was dissolved in the form of ammonium bromide.

To compare the sensitivity of measurement for the salt solution method, the dye method and the radioisotope method, the following figures are quoted. With homogeneous dilution of the respective additions to 100000 m^3 of water, one needs for the subsequent detection and for an evaluation of the results:

- (a) With salt additions and measurement of conductivity 400–1000 kg
- (b) With colouring by dyes 100–200 kg
- (c) With use of isotopes (NH_4Br) 20 mC = 0.3 g

The amount of radioactive matter required in each experiment is therefore exceedingly small.

The flow time measurements in rivers with the help of radioactive substances carried out in the Emscher have shown that measurements are possible over wide areas. It may be mentioned in conclusion that the Emscher had the following flow rates at the individual points of measurement (Figure 6):

Z 1	15 l/s
Z 2	2193 l/s
Z 3	4750 l/s
Z 4	12300 l/s

There is no doubt that the method of measuring with radioactive isotopes is superior to the methods used previously with respect to safety and accuracy.

METHODS OF CONTINUOUS MEASUREMENT OF WATER QUALITY

Contrary to other methods of measurement, it is impaired neither by obstacles to flow in the river nor by pollution in the water.

The question of ascertaining the direction of flow and, in particular, the dispersion of the sewage discharged by coastal towns into the sea is of great importance especially for seaside health resorts. It is well known that frequently the tidal currents move along the coast, so that the sewage introduced at one point is unavoidably carried to other parts of the coast. Dependent on the local conditions, the dirt particles carried along may be a danger to public health and make bathing impossible. Even with biologically cleansed waste waters there is still an inherent risk that pathogenic bacteria may be present in large numbers.

The path and the dispersion of sewage is not always easy to trace in large areas of water which also include natural and artificial lakes, because the material contained in the effluent often follows very different paths under the influence of wind and currents, and in the sea also of the tides. Thus the movement of the material floating on the surface is essentially governed by the wind and by surface currents. The suspensions contained in the sewage, on the other hand, follow to a greater extent the currents in deeper layers. Oils and fats form a thin, visible film on the surface near the sewage inlet into the waters which is easily carried along by the wind.

Probably the first attempt to investigate the dispersion of sewage feed streams in a lake was carried out in the USA in 1949 in a small lake with about 2 ha water surface.

Much more detailed investigations were carried out by Ruhrverband in a reservoir on the Ruhr river in 1952 and 1953. The reservoir has a length of about 2.6 km, a surface of about 2 km² and a water volume of approximately 3.2 Mio m³. The feed stream to the reservoir was about 40 m³/s. At the head of the lake, biologically clarified effluent entered at a flow rate of about 1.0 m³/s. To find the distribution of waste water in the reservoir, 70 mC of Br⁸² (half-life 36 hours) were added as ammonium bromide to the outflow of the purification plant. The effluent marked in this way was traced with a motor boat equipped with counter tube and counting register. Also, at different points in the lake, stationary counters had been installed. The investigations showed, as can be seen from *Figure 7*, that the effluent did not flow through the full width of the lake but ran in a narrow strip along the east bank.

A very interesting attempt to follow the paths of dispersion of effluents into the sea has been carried out at a point on the southern coast of England by Putman and Wildblood¹ entitled 'The use of radioactive and bacterial traces to follow sewage pollution in the sea', and also by Cochrane², 'The use of radioactive isotopes and characteristic bacteria in tracing sewage pollution in sea'.

In this area, two sewer outlets opened into the same bay on both sides of a bathing beach of 5 km length. At neap tide and inshore wind, sewage pollution had repeatedly been found on the beach. The investigation showed very conclusively in which way the sewage moved in the sea.

Another investigation aimed at preventing beach pollution has been carried out in the USA in recent years at the outlet of the Hyperion purification plant at Los Angeles with the help of radioactive isotopes. The results

have shown that measurement by radioactive isotopes is well suited to detect and trace the dispersion of wastes in waters of larger surface area.

From the examples briefly discussed above, it may be seen that valuable knowledge on flow phenomena and times of passage may be obtained with the help of radioactive isotopes. The principal requirements which

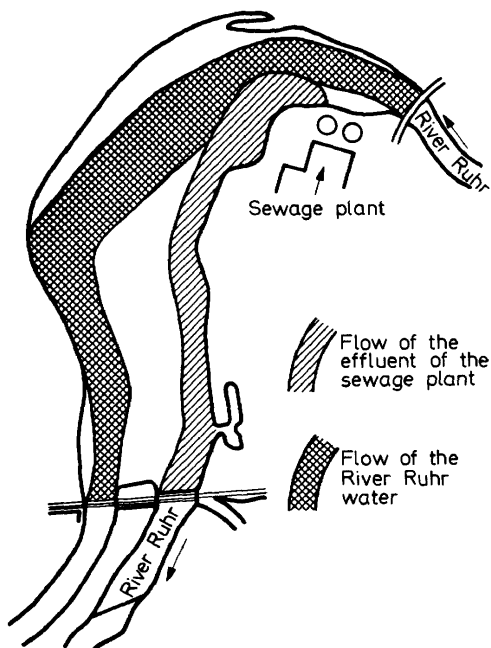

Figure 7. Flow of water and discharge of sewage in the river Ruhr.

have to met by an isotope for these investigations are solubility in water and sufficient lifetime for recording the impulse rate accurately at the counting amplifier, while the lifetime of the isotope and the amount of active substance applied still remain within such limits that radioactive contamination of the water does not occur.

QUALITY MEASUREMENTS

Some comments on quality measurements in effluents and inland waters and on continuous determination of substances contained in the water will now be made. Speaking about modern methods of analysis today always includes reference to mechanization and especially to automation. This consists of the replacement of manual operations during the course of analysis. The application of the Autoanalyzer (the Technicon instrument) in the analysis of water and effluent has been a major move forward in recent years.

Closely connected to the problems in chemical analysis are the developments in the field of automatic instrumentation, which are continuously

METHODS OF CONTINUOUS MEASUREMENT OF WATER QUALITY

growing in importance in view of legal requirements for the monitoring of effluent discharges into inland waters and for supervision of waters. Likewise, measurement and control techniques will increasingly gain importance in the future for the supervision and process control of purification plants for economic reasons alone.

As mentioned at the beginning, automatic effluent supervision by continuously measuring and recording instruments has considerable importance from a purely economic point of view. Again, an industrial firm should not be indifferent when saleable substances from the production go to waste in the effluent.

Not so very long ago the necessary and desirable investigations and controls in effluents and inland waters, for want of suitable instrumentation, could only be carried out by sampling on the spot and by subsequent, time-consuming treatment of the individual samples in the laboratory. In the last few years, the companies working in this field have developed instruments for the continuous measurement of a variety of substances contained in water or effluent which allow continuous measuring and recording, so that we do not have to resort to permanent manual sampling. I should like to enumerate just a few of today's many possibilities for measurement and control in effluent purification and water supervision.



Figure 8. A swinging electrode.

I need not dwell upon the continuous measurements of temperature and pH. They may be carried out today in a satisfactory manner and with sufficient accuracy. Difficulties with the electrodes in pH measurements have been overcome, and the continuous control, for example of a neutralization plant with lime or sodium hydroxide, dependent on the momentary value of the pH in the effluent, is a trouble-free operation. The same is true for the operation of decontamination plants of galvanizing industries. However, one cannot assume that such installations do not require any maintenance whatever. For example, a measuring electrode fouled to a great extent cannot, of course, give a true indication. *Figure 8* shows a swinging electrode which is not subject to clogging, and a pH instrument can be installed floating on the surface so that it may follow any fluctuation of the water level in a canal.

Specific attention must be paid to the oil pollution in effluents and waters. Development work at Ruhrverband has resulted in an oil detecting and recording device obtainable from the AEG company. The oil content of water is determined by the decrease in electrical conductivity. A rotating disc suspended in the direction of flow and just immersed below the surface carries the electrodes which indicate the conductivity of the water continuously. When oil floats on the surface it also enters between the electrodes, and the conductivity decreases in proportion to the amount of oil.

Figure 9 is a diagram of oil contamination by a waste oil emulsion which has been recorded in actual service. The surge of oil came abruptly and

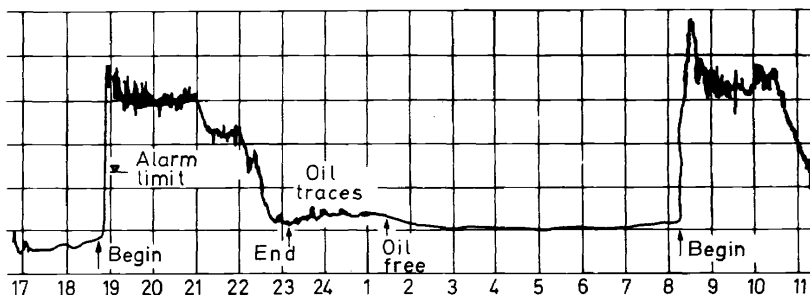

Figure 9. Diagram of oil contamination by a waste oil emulsion.

afterwards decreased slowly over 4 hours. The renewed contamination with oil also came abruptly. In the present state of development the instrument gives only a qualitative indication of the oil influx, but it will be easy to proceed to quantitative measurement.

High salt concentrations suddenly appearing in purification plant intakes may have an exceedingly unfavourable influence on the mechanical as well as on the biological part of the operation (black drains of two-story digestion tanks). Effluents with high specific salt content have a high density, so that they are caught in the settling tank as a cushion, thereby reducing the effective volume for clarification for the following effluents with lower density to such an extent that insufficient purification results. In the biological part

METHODS OF CONTINUOUS MEASUREMENT OF WATER QUALITY

of a treatment plant, high salt concentrations may lead to plasmolysis of the bacteria and, by this, make effective purification illusory.

For the continuous measurement of the conductivity, and, through this, of the salt concentration in effluent or waters, commercial conductivity meters with platinum electrodes immersed into the effluent or river water to be examined are of no use since the platinum foils become coated with oil and dirt in a short time, in spite of constant cleaning efforts by wipers or similar devices.

The Dephimeter, manufactured by the Dräger company in recent years, is equipped with an electrodeless measuring cell, a so-called high-frequency probe, which has stood the test very well and may be universally applied. Dephimeter measurements carried out over a period of many months in a strongly polluted and oil-bearing effluent have been fully satisfactory. Cleaning of the probes has not been necessary.

As you may see from *Figure 10*, salt inflows of short duration may be unambiguously detected. From a pump station automatically delivering effluent from a drainage area to a purification plant about every 2 hours,

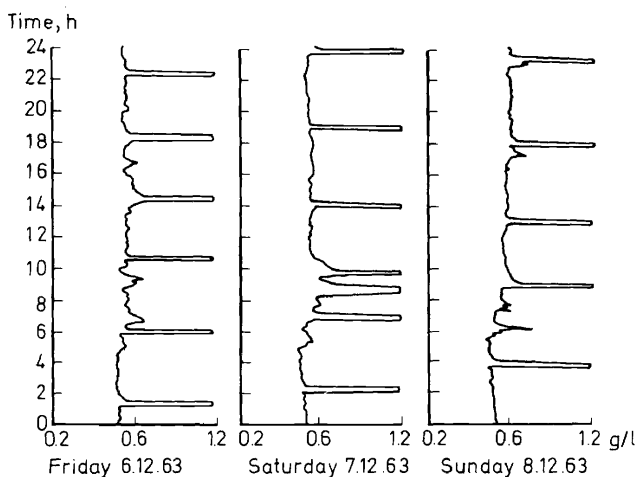

Figure 10. Recordings from the Dephimeter.

considerable salt concentrations of up to 1.2 g/l entered the purification plant during an interval of only 10 minutes. These short-time surges of salt could not be detected in the plant intake with normal sampling. From the Dephimeter measurement, it could be established that saline waters entered from leaking pipe lines, a fact which had not been known at the pump station.

Continuous information on the sludge content of domestic or industrial effluent discharged into the sewers is, on the one hand, important for the operation of the purification plant. On the other hand, it may be equally significant in an industrial plant for control purposes in order to check that no material from the production is lost with the effluent.

Qualitatively, pollution of an effluent may be very well displayed in so-called filter pictures. A fixed amount of water is filtered through a filter of specified size. From the colour and the intensity of the filter picture it is possible to arrive at conclusions on the concentration of sludge in the effluent. These filter pictures may be taken continuously by the following device. A vessel is filled with the effluent to be investigated in the desired time intervals. The water is then run through a filter travelling underneath the vessel. Subsequently, the filter is dried in a blast of hot air and sprayed with a fixing solution for conservation of the filter picture. Afterwards the finished filter strip is wound up again and may be taken off for evaluation at any time. *Figure 11* shows filter pictures taken of an effluent and *Figure 12* shows pictures of river water.

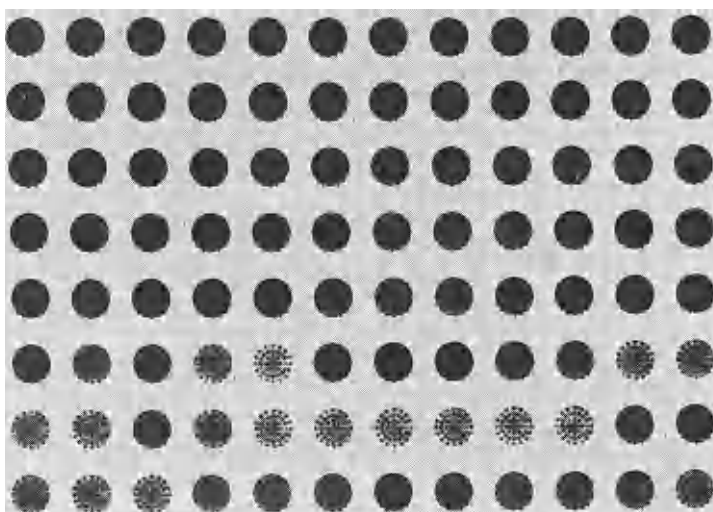

Figure 11. Filter pictures of a stream, settling time 30 min.

In recent years instruments have been developed which allow a continuous volumetric determination of the sludge content in effluents. One instrument records the sludge content of the effluent after a settling time of 2 hours by taking pictures on a film strip. An average sample of the effluent which is to be examined is automatically fed from a collecting vessel to the settling glasses which are held on a rotating table. From the time of filling a settling container with effluent it takes 2 hours until this glass has moved in front of the camera. The camera is then automatically released and the sludge content in the settling glass recorded. The photographed container moves along, is discharged automatically by tilting and rinsed with pure water. It is then ready for the next measurement. In the meantime, more containers with sludges settled to the bottom have passed the camera in the desired intervals, and the corresponding pictures have been taken. By advancing the film in the camera one gets an image of the sludge content in the effluent for each hour during the day (*Figure 13*).

METHODS OF CONTINUOUS MEASUREMENT OF WATER QUALITY

Since with the instrument just described the results can be evaluated only after the film has been developed, we have re-designed it so that the amount of sludge in an effluent is detected by a photo-electric device. *Figure 14* shows the basic features of such an instrument—the settling glass with a definite sludge level, the photocell and, schematically, the indicator on the right-hand side.

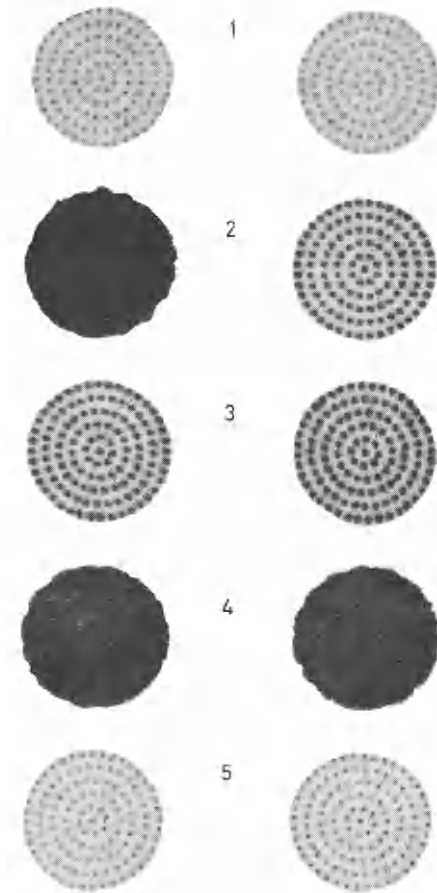

Figure 12. Filter pictures of river water.

Apart from the direct measurement of sludges with concurrent recording which is possible with the instrument just described, it is also feasible to measure and record the sludge content of an effluent by the absorption or reflection of light. In our experience instruments based on absorption measurements are suitable for the photoelectric determination of the sludge content in an effluent since they are insensitive to the colour of the sludge. When instruments based on the reflection of light are applied for this measurement it is impossible to determine dark sludges unambiguously.

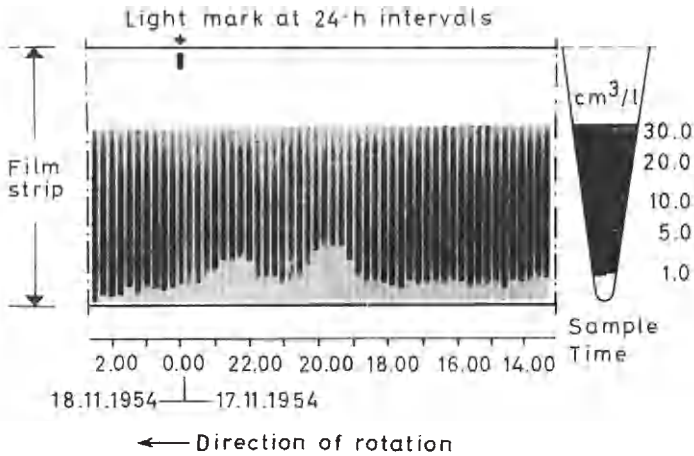

Figure 13. Automatic measuring and recording of sludge content on a film strip.

For measurements of turbidity and, by this, for continuous determinations of sludge content, the instruments of the firms Sigrist, Zürich, and Askania, Berlin-Friedenau, have been tested successfully during the last few years. Both devices have been given very thorough investigations to determine their possible application and their accuracy under a variety of conditions. Figure 15 shows the results of absorption measurements with both instru-

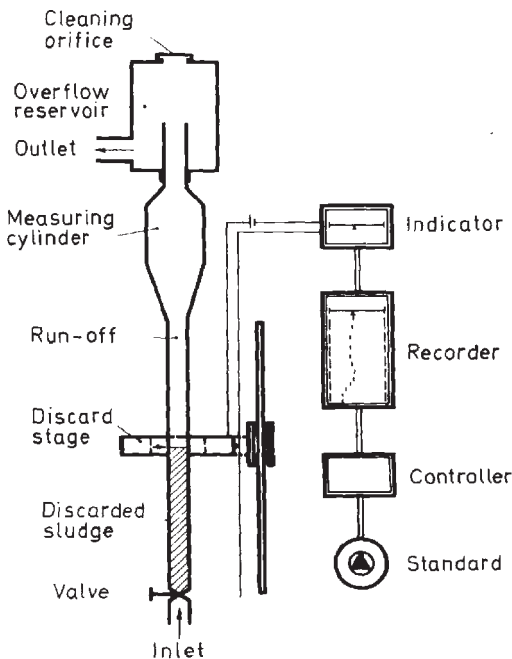

Figure 14. Sludge purification measuring equipment.

METHODS OF CONTINUOUS MEASUREMENT OF WATER QUALITY

ments used for monitoring continuously water which is strongly polluted with sludges. Line 1 indicates the amount of sludge determined in the usual manner in settling containers of the Imhoff design. Line 2 shows the results of measuring with the Askania instrument and line 3 those of the Sigrist instrument. A comparison of the individual curves with the sludge content in the water found in the settling containers showed a good enough agreement for operation under plant conditions.

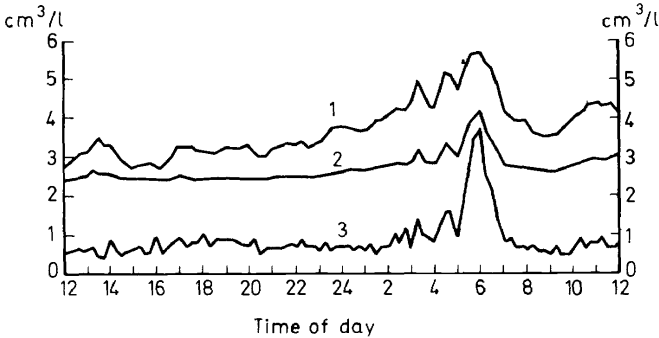

Figure 15. Relative turbidity using two different measuring systems. Line 1: Sludge determined after two hours; line 2: turbidity index using Askania instrument; line 3: turbidity index using Sigrist instrument.

Continuous measurements of the oxygen content have great importance in control and regulation of the aeration of activated sludge plants for reasons of power economy alone.

The purification effect of an activated sludge plant may be controlled with regard to its energy consumption essentially by two factors, dependent on the prevailing effluent concentration and on the cleaning effect which has to be attained.

(1) By the control of the activated sludge content in the aeration basin, adjusted to the concentration of the effluent.

(2) By the automatic control of the required oxygen content in the aeration basin, which in turn is governed by the sludge content, the sludge activity and the effluent concentration.

The continuous adjustment and control of the content of activated sludge in an aeration basin may be easily accomplished by using a suitable modification of the automatic instruments for sludge content measurement already described.

For a number of years much attention has been paid to the problems of continuous determination of oxygen. The methods known for the determination of oxygen dissolved in waters or in effluent are founded on two principles of measurement: (1) on phase exchange with subsequent determination of the oxygen content by a Magnus instrument; (2) on electrochemical measurement.

In the phase exchange technique, the oxygen dissolved in the water is flushed out with an inert gas. The oxygen content in the inert gas is subsequently found by measuring the paramagnetism. Nitrogen or propane are used as inert gases. For the paramagnetic measurements the Magnus

instrument of Hartmann und Braun company has given good service. In field measurement of the oxygen content of an activated sludge—sewage mixture, favourable experience has so far been gained with an instrument manufactured by Chlorator GmbH which is shown schematically in *Figure 16*. A characteristic feature of this instrument is a special design of the phase exchange device.

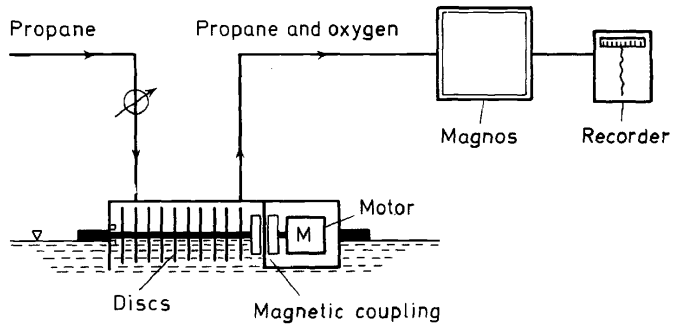

Figure 16. Oxygen measurement using phase exchanger type 'B'.

It consists of a disc scrubber floating on the surface. A series of discs, separated by short distances, is held on a slowly rotating shaft. The discs are immersed about half way into the water or sewage, while a hood separates the discs from the outer atmosphere. Propane is introduced under the hood

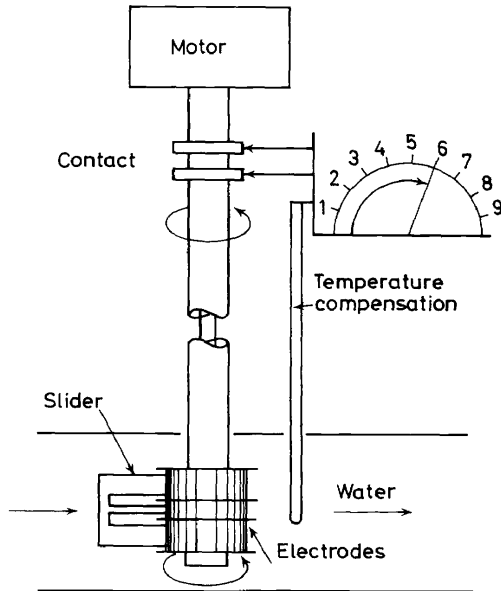

Figure 17. Oxygen determination.

METHODS OF CONTINUOUS MEASUREMENT OF WATER QUALITY

as an inert gas. A film of water with an oxygen content corresponding to the content in the effluent adheres to the rotating discs. With a constant flow of inert gas, the oxygen dissolved in the film diffuses into the inert gas phase as determined by the concentration-dependent equilibrium. This inert gas phase charged with oxygen is fed to an oxygen analyzer (Magnos instrument), and the oxygen concentration is determined from the paramagnetic properties of oxygen.

The second basic instrumental principle for oxygen determination in effluent is electrochemical measurement. When two electrodes of metals of

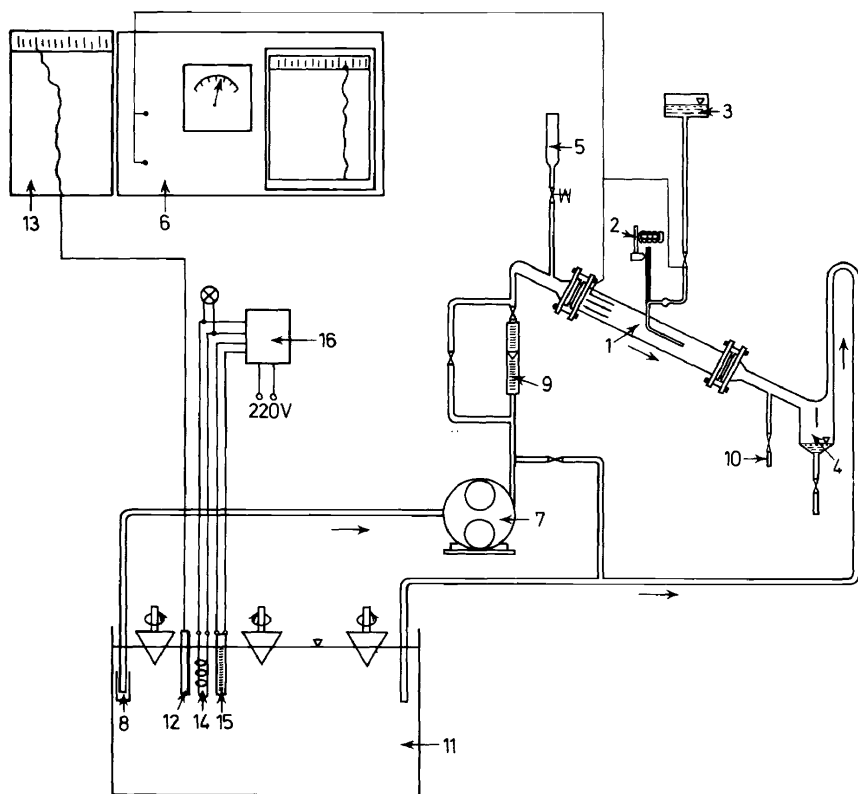

Figure 18. Continuous polarographic oxygen determination. 1, Measuring cell; 2, impulser; 3, mercury reservoir; 4, mercury cut-off; 5, added chemicals; 6, voltage source and regulator; 7, toothed wheel pump; 8, sample draw-off device; 9, rotameter; 10, sample point for oxygen determination; 11, aeration basin; 12, thermometer; 13, thermograph; 14, heater; 15, contact thermometer; 16, relay.

different electropositivity are immersed in the water to be investigated, a current will flow between them whose intensity is proportional to the oxygen concentration in the water. In the electrochemical method it is difficult to attain constancy of the free effective electrode surfaces which have a decisive influence on the measuring current. Methods using solid electrodes or a combination of a solid and a liquid electrode may be distinguished.

When using solid electrodes for continuous measurements the electrode surfaces are either protected from fouling or clogging by plastic membranes or cleaned chemically and mechanically. Mechanical cleaning of the electrodes, as done in the Stracke instrument, can be carried out simply and easily in practical operation. This instrument, shown schematically in *Figure 17*, is capable of directly measuring the mixture of effluent and activated sludge in an aeration tank which is to be examined for its oxygen content. The mixture is passed by a pump over the rotating electrodes with a velocity of more than 1 m/s. Sediments and precipitates on the electrodes are concurrently removed by wipers. *Figure 18* shows an instrument ready for use.

Continuous paramagnetic oxygen measurements with the Magnos instrument may be applied in practice in a variety of ways. This method can (1) determine the oxygen utilization of the air pumped into the aeration basin of an activated sludge plant; (2) determine the oxygen feed introduced by different aeration systems into the effluent from an activated sludge plant.

Investigations of the oxygen utilization in the cross-section of an activated sludge tank with pressure aeration, carried out by paramagnetic oxygen determinations, have yielded very interesting results, as shown by *Figure 19*.

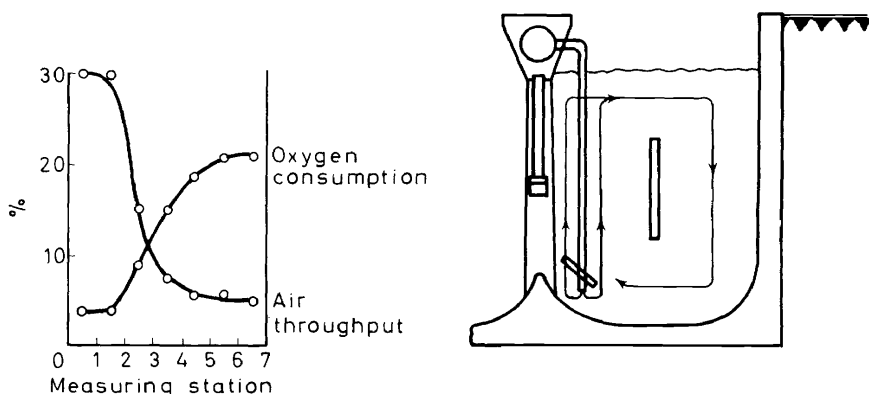

Figure 19. Oxygen consumption in a purification basin.

The oxygen utilization in this plant increased from 4 per cent at the side of air intake to 21 per cent at the opposite side of the aeration basin. On average, the utilization of the oxygen introduced with the air was 4.6 per cent. When such measurements are made part of the surface of the activated sludge plant is covered by a tank and the air collected under this tank goes to the Magnos instrument.

At important points of a river or a river system, and also at the point of junction of a river system to a larger volume of water, continuous monitoring of water quality may be necessary.

The selection of the point of sampling in the cross-section of a body of water depends on mixing conditions. With effective mixing, it is of little influence whether samples are taken directly from midstream or from the

METHODS OF CONTINUOUS MEASUREMENT OF WATER QUALITY

regions towards the banks. In any case, samples may not be taken from the nearly stagnant regions along the banks. This would certainly produce results from any measurement which are not characteristic for the body of water. This is especially true for the oxygen content, since in summer strong irradiation by sunlight and thick overgrowth of the banks may cause, by biological aeration, a significant increase of oxygen content in sunny spots over that prevailing in the midstream or in regions of shadow. With improper selection of the measuring or sampling point, it may appear that the oxygen supply of the water is still assured, while critical concentrations or a deficit of oxygen prevail in the centre of the flow.

The tasks and the importance of monitoring stations, seen in the context of a systematic water economy, have already been described many times in the technical journals during the last few years. Emscher genossenschaft and Lippeverband have operated measuring and monitoring stations for more than 18 years. *Figure 20* shows a scheme of a similar monitoring station at

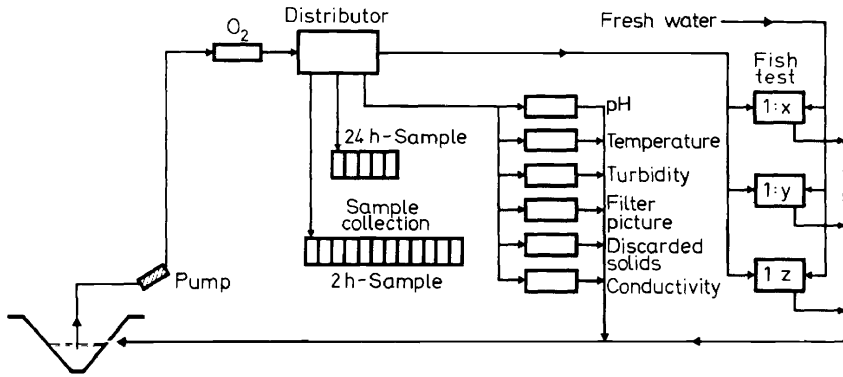

Figure 20. Monitoring system.

Wesel, just upstream of the junction of the river Lippe to the Rhine. In this station, continuous measurements are made of: water temperature; air temperature; oxygen content; conductivity; pH; turbidity; sludge content; toxicity to fish. Concurrently, samples are taken automatically from the water.

A few months ago a large supervision station, equipped with all the modern measuring and monitoring installations, has been put in operation at the Rhine just upstream of the point where it enters the Netherlands from Germany. All the supervision stations in Germany are equipped with fish tanks where tests are made to determine whether noxious or poisonous material has been discharged with the effluent. This method of testing the water quality has given good service along with the other continuous measurements and investigations.

With the increasing development of automatic monitoring instruments, for effluent purification as well as for supervision of waters, we have to concern ourselves intensively in the future with the problems of transfer,

W. HUSMANN

collection and evaluation of data in order not to be suffocated in a flood of recorder charts. Our objective must be to convert the data quickly into the most useful form as a decision aid. This is the only way to attain the required optimum effect of the recent development measurement techniques for the quality control of water.

REFERENCES

- ¹ J. L. Pitman, Anne M. Wildblood and June E. Robson. *Water Sanit. Engr* 6 (3), 99 (1956).
- ² H. B. Cochrane, *Surveyor CXV*, No. 3339, 173 (1956).