

SPREADING BEHAVIOUR AND ACIDOLYSIS OF THE SILOXANE LINKAGE AS VARYING WITH THE DONOR-ACCEPTOR PROPERTIES OF THE ORGANIC SUBSTITUENTS

W. NOLL

*Inorganic Department, Farbenfabriken Bayer AG,
Leverkusen, Germany*

A complex consisting only of silicon and oxygen atoms shows a state of linkage which may be considered a resonance linkage between the following three limiting forms which contribute in about equal proportions:

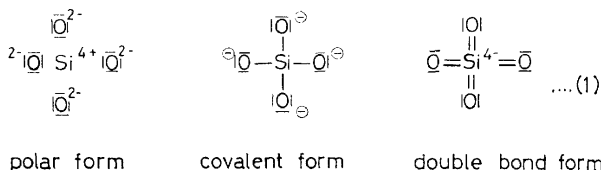

Organic groups R which are electron donors cause a weakening of the Si—O—Si linkage by increasing polarization, while R groups, which are electron acceptors, strengthen the linkage by an increase in the double bond character. The influence on the Si—C linkage is in the reverse direction¹:

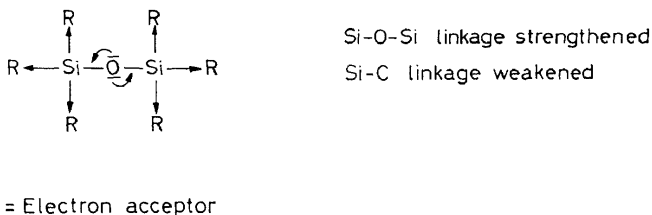
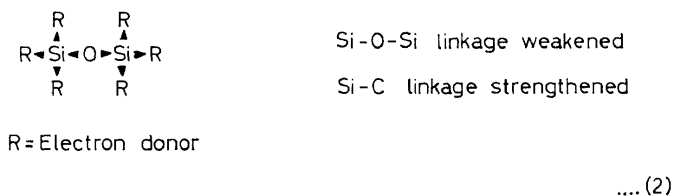

The following investigations will show that the alteration of the electron density at the siloxane oxygen, owing to the donor-acceptor properties of the R substituents, influence in a very sensitive manner the physical and

chemical behaviour of the siloxanes. This will first be illustrated by studies on the spreading behaviour.

SPREADING BEHAVIOUR OF SILOXANES

Although a knowledge of the spreading behaviour is of considerable interest in view of the great practical importance of the interface activity of silicones, measurements of this kind have been carried out rather rarely. Our knowledge is mainly derived from a paper published in 1947 by Zisman and co-workers². With our own work, we intended to investigate systematically the spreading behaviour of the siloxanes as varying with the molecular structure and the chemical substitution.

For the measurements we used a film balance with the characteristic feature that, instead of the traditional "point after point" measurements, it allows a continuous and self-registering recording of the F/A isotherms. This film balance may have a circular (*Figure 1*³, *4*) or a rectangular (*Figure 2*⁵) tray.

The possibility of continuously recording spreading curves by means of the film balance proved to be extraordinarily useful particularly in the case of siloxanes, because their F/A-isotherms have no strongly pronounced points of inflection. This is shown by the F/A-isotherm of *Figure 3* representing a typical film pressure *vs.* area diagram of a dimethyl polysiloxane. Comparison with stearic acid at once shows very marked differences: the softness of the path of the curve, the considerably greater area requirement in spite of about comparable molecular size, and the considerably lower pressure level reached in the course of the compression. Obviously, in the case of the siloxanes, quite different states of orientation are realized than in the case of the carboxylic acid.

The F/A-isotherms were evaluated by comparing the measured areas (A values) with the values for the area requirement of the siloxane chain in different, constructively conceivable states of order. It was thus necessary to evaluate four points of inflection of the curve designated with the symbols A₁ and A₂, B and C (*Figure 3*). Amongst them, A₁ is least pronounced and on many diagrams no longer measurable with certainty. What accuracy could be reached between the measured A values and those calculated for the molecular orientation concerned is shown in *Table 1*.

The result of a detailed discussion of the F/A-isotherms of a dimethyl polysiloxane⁴ largely independent of its chain length is as follows. In the case of an area offer greater than that of the area A₁, the siloxane chains lie

Table 1. Measured and calculated values $A[\text{\AA}^2]$ for the area requirement of MD₁₄M on water

<i>Inflection point</i>	<i>a</i> (<i>measured</i>)	<i>b</i> (<i>calculated</i>)	<i>Mean</i> $\left(\frac{a-b}{b} \cdot 100\right)$
A ₁	422 ± 7.2	439	- 3.9
A ₂	300 ± 7.0	327	- 8.3
B	215 ± 4.2	213	+ 0.9
C	115 ± 6.1	131	- 12.0

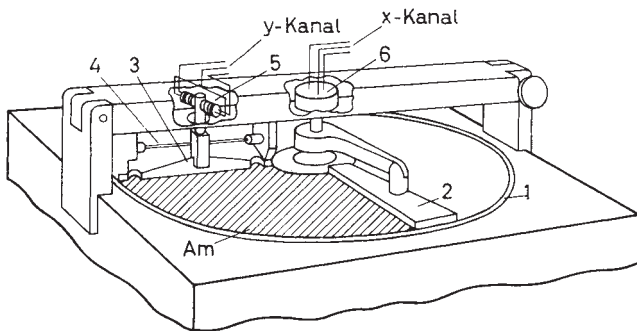

Figure 1. Continuously measuring and self-registering film balance having circular tray [1, trough; 2, barrier for compression and expansion; 3, film pressure sensitive barrier; 4, torsion wire; 5, inductive displacement recorder; 6, potentiometer]

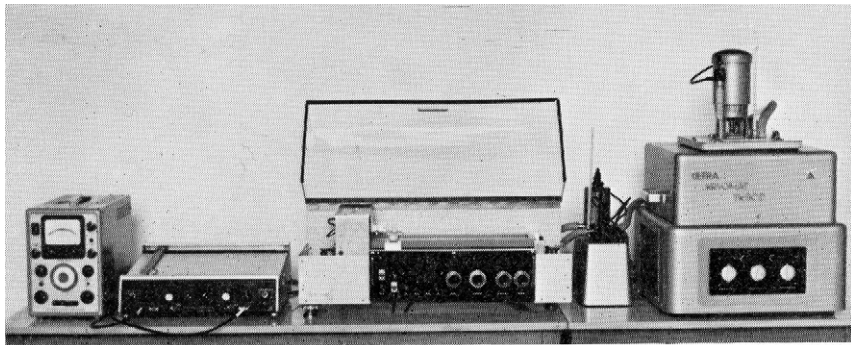

Figure 2. Continuously measuring and self-registering film balance having rectangular tray

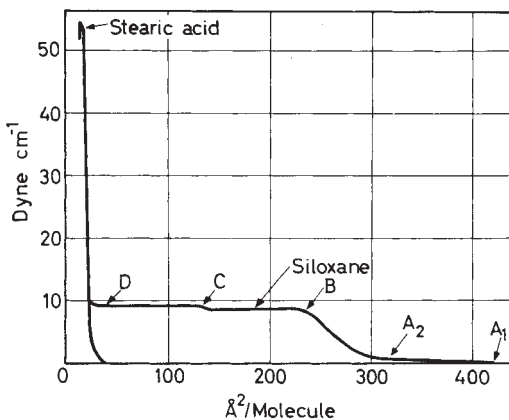

Figure 3. F/A-Isotherm of a dimethyl polysiloxane MD₁₄M and stearic acid (for comparison)

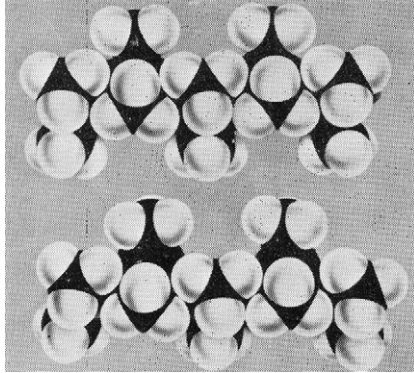

Figure 4. Dimethyl siloxane chain in caterpillar form

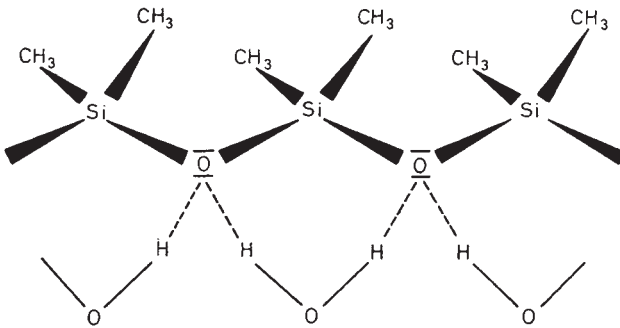

Figure 5. Hydrogen bridge linkage between dimethyl siloxanes and water

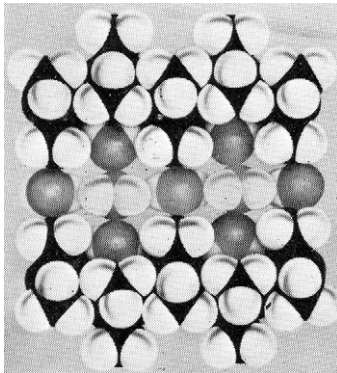

Figure 6. Surface hydrate A₁

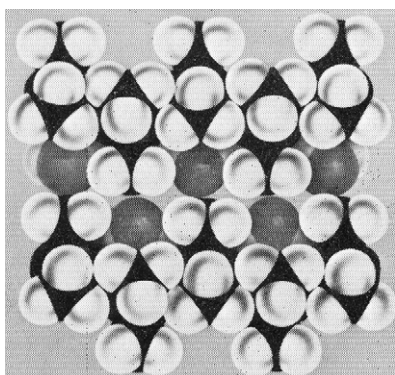

Figure 7. Surface hydrate A₂

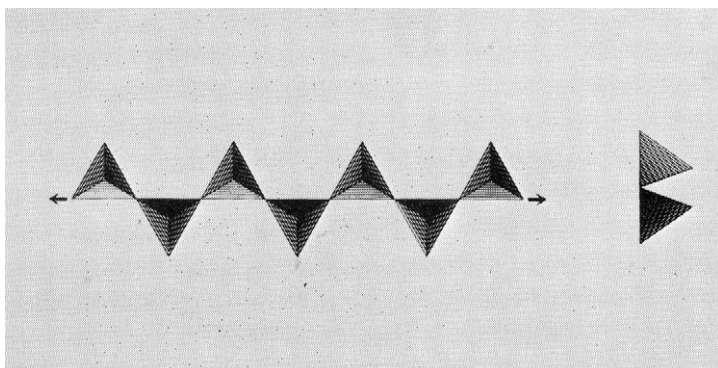

Figure 8. Pyroxene chain

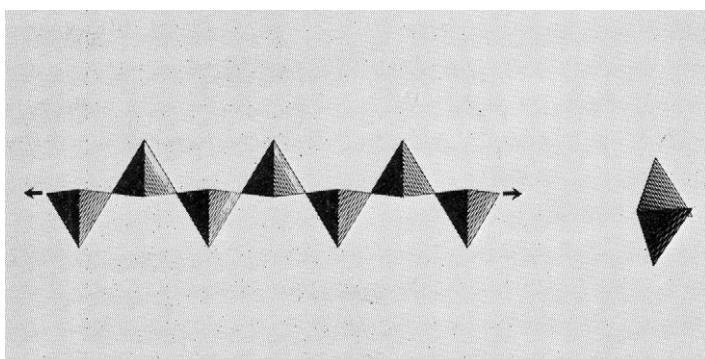

Figure 9. Spreading chain; the CH₃* groups being in the free tetrahedron corners are directed upwards and downwards

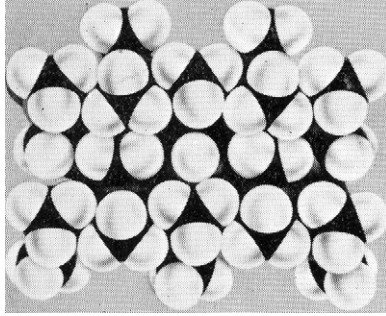

Figure 10. Densest packing in the film B. A view onto methyl groups

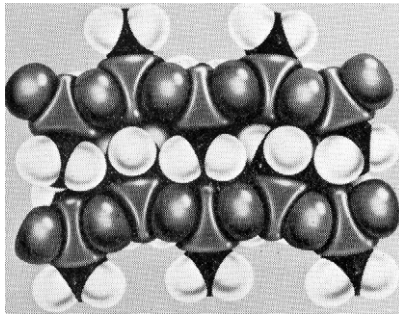

Figure 11. Densest packing in the film B. A view onto siloxane chains

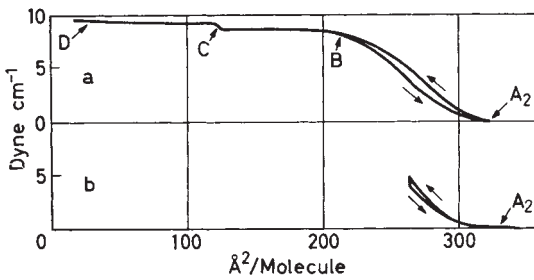

Figure 12. Hysteresis B–A₂ in case of spreading of MD₁₄M

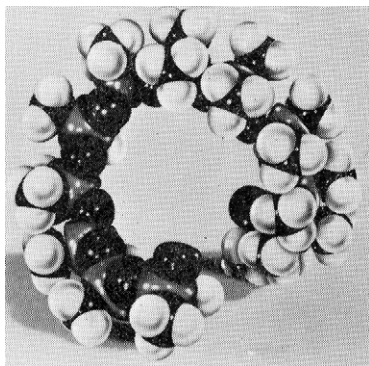

Figure 13. Shape of a siloxane helix

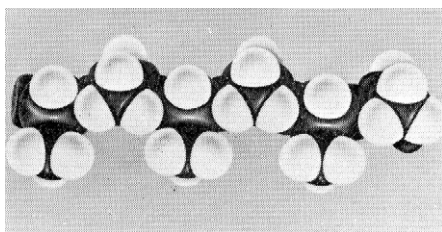

Figure 18. Isotactic γ_s -form of the methyl hydrogen siloxane chain

SPREADING OF SILOXANES

on the water surface in a caterpillar-like stretched form (*Figure 4*) in such a manner that the siloxane dipoles dip into the water surface, while the methyl groups turn away from it. The stretching of the chain and the contact of the siloxane dipoles with the surface of the water are reinforced by hydrogen bridge linkage between the protons of the water and the siloxane oxygen. The increase in electron density at the siloxane oxygen owing to the methyl substituents promotes the formation of hydrogen bridges (*Figure 5*).

Compression of the film reduces the free path between the molecules, at first in gas-like distribution, until, in the points A_1 and A_2 , the first states of order are reached (*Figures 6 and 7*). These may be looked upon as two-dimensional solutions of silicone oil in water or water in silicone oil with a defined ratio of siloxane molecules to water molecules ("surface hydrates"). A detailed analysis of the points of inflection shows that the molecular chain is not present in a form corresponding to that of a siloxane chain as known from the lattices of the pyroxenes ("pyroxene chain"). A structure is rather formed which may be termed "spreading chain" and which is distinguished from the pyroxene form by the fact that the methyl groups CH_3^+ located in the free corners of the tetrahedral structural elements do not dip into the surface of the water but are lifted off from it, which is to be expected owing to the hydrophobia of the methyl groups (*Figures 8 and 9*).

As parallel chains may be toothed with one another in a zip-like manner, a densification of the film may take place in the case of further area reduction beyond point A_2 , without any change taking place in the principal orientation of the molecular chain with respect to the surface of the water. The densification process is terminated in point B in which the molecules are oriented in the manner characterized by *Figures 10 and 11*. The surface of the water is covered with respect to the outside by a densest packing of methyl groups (*Figure 10*). As a discussion of the atomic model shows, the toothing of the chains with one another is not possible without overcoming a certain steric hindrance. This and the overcoming of the repulsive forces in the case of the molecules closely approaching one another appears to account for why the only really strong pressure rise in the F/A-isotherms is to be observed within the range from A_2 to B. Another fact that goes to prove the steric hindrance particularly within this range is that in the case of pressure release, i.e. expansion of the film, a hysteresis is observed within the range B to A_2 , and this hysteresis is *only* in that very range (*Figure 12*). Thus, while all other molecular orientations are downright reversible, the disentanglement of the molecules in this range lags behind the increase of the area offer.

In a monomolecular film, further densification beyond point B while maintaining the caterpillar-form is impossible. Pressure increase or area reduction means however a successive lifting off of the siloxane chains from the surface of the water. As soon as they are no longer sufficiently under the influence of the water molecules, they roll up to helical form, i.e. to a form in which dipoles compensate themselves. The energy thus gained largely balances the energy required for the lifting off of the dipoles from the surface of the water. Therefore, the pressure rise within the range B to C is only very small. The molecular orientation in the point C should therefore be represented by a monomolecular film consisting of a densest packing of molecular helices lying with their axes parallel to the surface of the water

(Figure 13). From the area required, it may be concluded that helices are involved which contain a mean of six $[(\text{CH}_3)_2\text{SiO}]$ units per helical turn. If the area offered is reduced beyond point C, the film will collapse.

Following a wide range of the curve, molecular orientation is therefore governed by the strong association tendency of the siloxane linkage to the surface of the water. The F/A-isotherms obtained when spreading on non-aqueous, non-polar liquids provide no indication as to the molecular chains assuming stretched forms like on water. When spreading on paraffin oil, the chains of the dimethyl siloxanes lie, obviously from the very beginning, on the surface in helical form, i.e. they orient themselves with their organic groups to the paraffin oil.

Now it was conceivable that by increasing the proton concentration of the aqueous phase the hydrogen bridge linkages might be reinforced and thus perhaps also the orientation phenomena influenced. The results of these studies are presented in Figures 14–18. As can be seen from Figure 14⁶, while in the p_{H} range of 9.1 to 3.0 the characteristic F/A-isotherm is found, its course changes noticeably from point B when the p_{H} value is lowered to 1.4. The change is still more pronounced at $p_{\text{H}} = 0.3$. This means that the lifting off of the siloxane chains from the surface of the water is increasingly rendered more difficult owing to the reinforcement of the hydrogen bridge linkage and the steadily increasing loading of the siloxane chain by the water ballast. Rolling-up to form a helix becomes impossible and the energy required for separating the siloxane from the surface of the water becomes greater and greater.

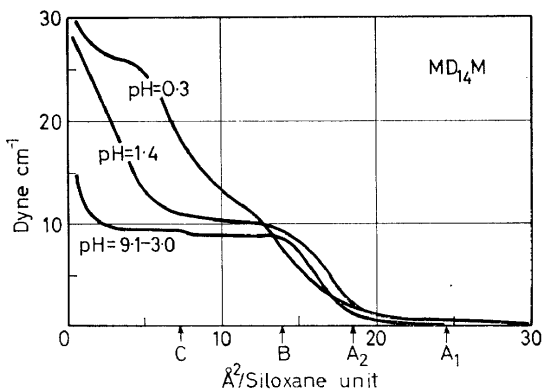

Figure 14. F/A-Isotherms of dimethyl siloxanes on water at various p_{H} values

When the silicon atoms are at least partly substituted with phenyl groups, i.e. electronegative substituents, the F/A-isotherm assumes a totally different character (Figure 15). The spreading power is greatly reduced, which is understandable, in the sense of what has been said, from the fact that owing to the lower electron density at the oxygen atom, the ability to form hydrogen bridge linkages and thus the association to the surface of the water is reduced.

When higher alkyl groups are introduced into the siloxane chain in addition to the methyl groups, the typical curve character of the dimethyl

SPREADING OF SILOXANES

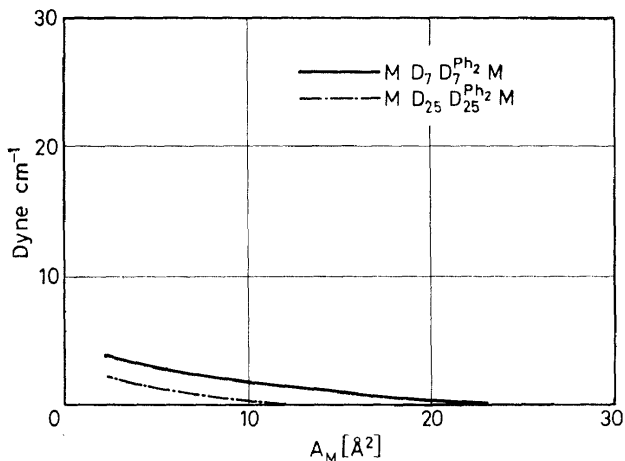

Figure 15. F/A-Isotherms of methyl phenyl siloxanes on water

siloxanes is lost. Methyl ethyl siloxane already shows a changed behaviour (Figure 16). The paths of the curves indicate that the spreading power and the tendency to form films is lost with rising C numbers. Thus, the picture approximates that of the paraffins, which are known to have such a low affinity to the surface of water that they do not spread at all.

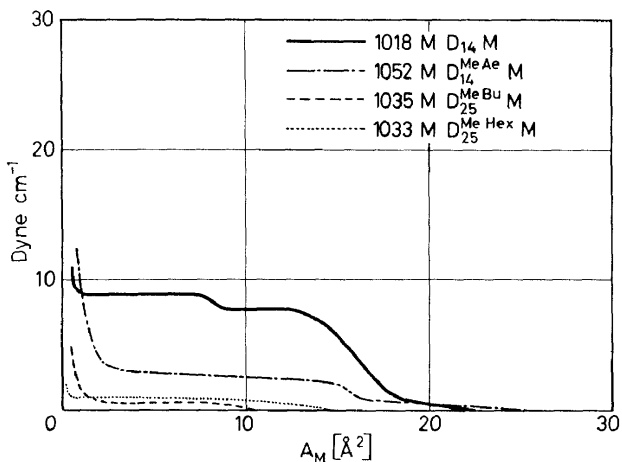

Figure 16. F/A-Isotherms of methyl alkyl siloxanes on water

Observations made when investigating the spreading behaviour of methyl hydrogen polysiloxanes are particularly interesting⁶. It was doubtful from the very beginning whether, because of the susceptibility of the Si—H linkage to hydrolysis, it would be possible at all to get hold of the F/A-isotherm of a methyl hydrogen polysiloxane within the duration of the measurement. The continuously operating, self-registering equipment we

SPREADING OF SILOXANES

Summarizing, it may be said that only dimethyl and methyl hydrogen siloxanes are able to spread on the water surface with appreciable spreading pressures. Alkyl substituents with higher C numbers or phenyl groups very quickly reduce the spreading power. This is distinctly shown by the drop of the area pressure in point C with rising carbon number of the alkyl group (*Figure 19*). The two siloxanes mentioned and, at best, also methyl ethyl siloxanes are the only ones in the films of which the molecular re-orientations discussed take place in a recognizable manner. Obviously they alone are able to form a surface film corresponding to the B point, in which owing to densest packing of the organic groups the spreading base is completely covered by hydrocarbon radicals.

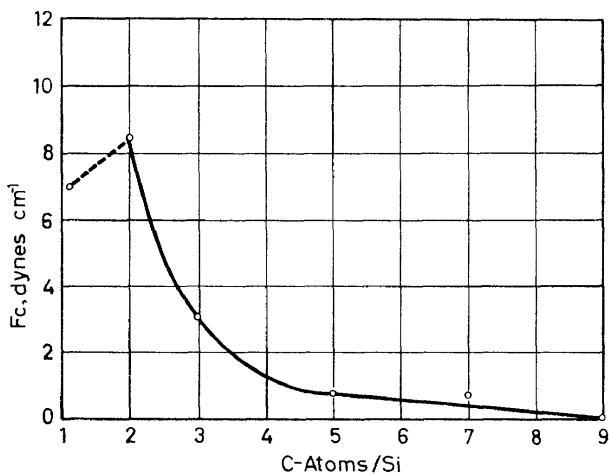

Figure 19. Variation of the spreading pressure (F_c) with the C number of the alkyl groups in methyl alkyl siloxanes

These statements underline the special position the methyl silicones have held for many years in technology because of their surface activity and make it understandable why it is particularly they which have come to the fore so very much as compared with other organosiloxanes. *As to their interface-chemical behaviour, methyl and methyl hydrogen siloxanes are not the rule among the siloxanes, but the exception.*

It is interesting that the extrapolation of the relation between film pressure F_c and hydrocarbon number of the alkyl radical should result in a pressure for the methyl hydrogen siloxane which is higher than that of dimethyl siloxane (*Figure 19*). Actually, however, it is lower. This indicates that the hydrogen, which as a substituent has taken the place of a methyl group, does not act like the latter as an electron donor, but rather as an electron acceptor and thus rather reduces than increases the electron density at the siloxane oxygen.

ACIDOLYSIS IN SILOXANES

After these results have shown to what great an extent the linkage conditions in the siloxane linkage influence the interface-chemical behaviour, the

second part of this paper will prove by means of the data resulting from measurements as to how sensitively it reacts, regarding the chemical behaviour, to the state of linkage in the case of acidolytic cleavage.

A possibility of following up the acidolysis according to the equations (3) and (4)



by measurements resulted from the following observation.

When determining the water content of hexamethyl cyclotrisiloxane by titrating with Karl Fischer's reagent it was found that the fast reaction of the water was followed by a further reaction in which hydrogen iodide formed during the Karl Fischer titration of the water (as a proton acid) decomposed the Si—O—Si linkage; the silanol groups thus formed react with Karl Fischer's reagent⁷ according to the equation 5

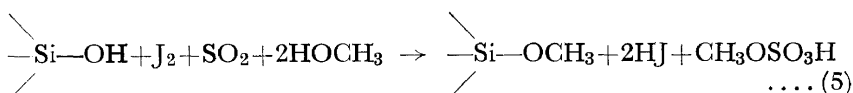

An investigation of the reaction kinetics showed that the reaction given in equation (5) takes place very quickly and that the decomposition of the oxonium complex in equation (4) is decisive for the velocity. The reaction is of the first order and takes place at very different speeds depending on the substitution and the structure of the siloxanes (*Figures 20 and 21*).

The half-life which we determined for a number of siloxanes on the basis of our measurements may therefore be considered a measure of the reactivity. As can be seen from *Table 2* it shows great differences.

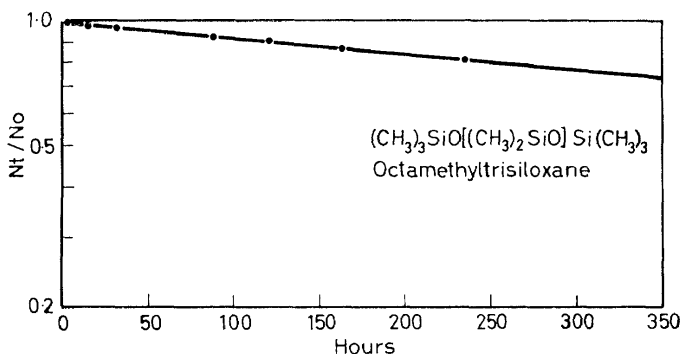

Figure 20. Cleavage of octamethyltrisiloxane by HJ

SPREADING OF SILOXANES

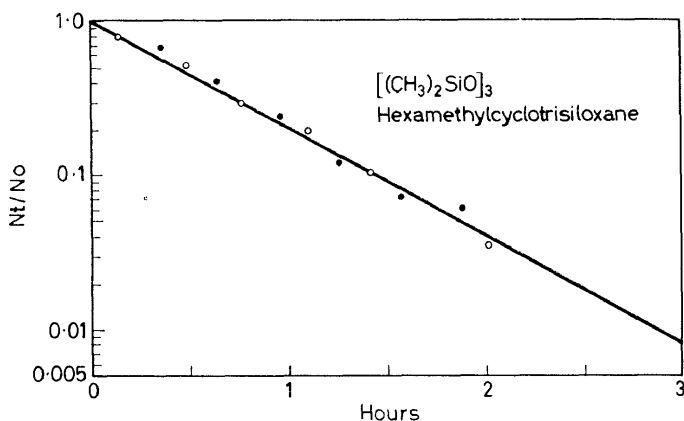
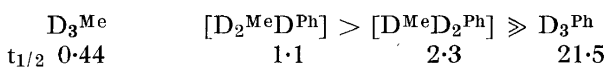

Figure 21. Cleavage of hexamethylcyclotrisiloxane by HJ

 Table 2. Half-lives ($t_{1/2}$) and decay constant (k) of the acid cleavage of various organopolysiloxanes

Organopolysiloxane (Silanols for comparison)	Abbreviation	$t_{1/2}$ (h)	$k \cdot 10^3$ (h^{-1})
Diphenylsilane diol	—	0.05	—
Diethylsilane diol	—	0.05	—
Hexamethylcyclotrisiloxane	D_3^{Me}	0.44	1575
Hexaphenylcyclotrisiloxane	D_3^{Ph}	21.5	32
Hexamethyldisiloxane	M_2^{Me}	36	19
Octamethylcyclotetrasiloxane	D_4^{Me}	175	3.96
Decamethylcyclopentasiloxane	D_5^{Me}	310	2.2
Octamethyltrisiloxane	MDM^{Me}	780	0.9
Dodecamethylcyclohexasiloxane	D_6^{Me}	1000	0.6
Octaphenylcyclotetrasiloxane	D_4^{Ph}	∞	0

The influence of substitution in the case of equal structure is shown by the following series:



The conspicuous jump of the reactivity from the third to the fourth member of the series is caused by the ring remaining reactive as long as at least one oxygen atom is there which is subject to only "unilateral" electron withdrawal (Figures 22 and 23)⁸.

The influence exercised by the number of equal substituents per Si atom is apparent from the example

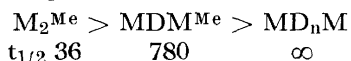

Finally, the role of the structure in the case of equal substitution is demonstrated by the relations

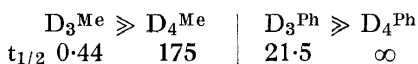

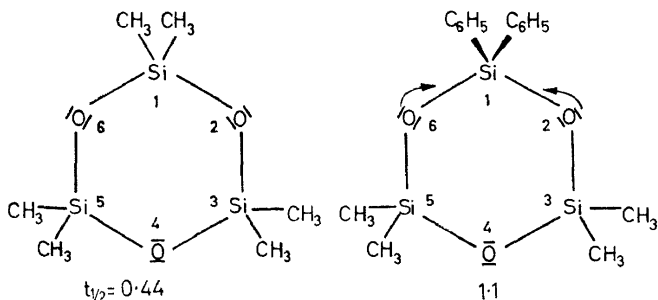

Figure 22

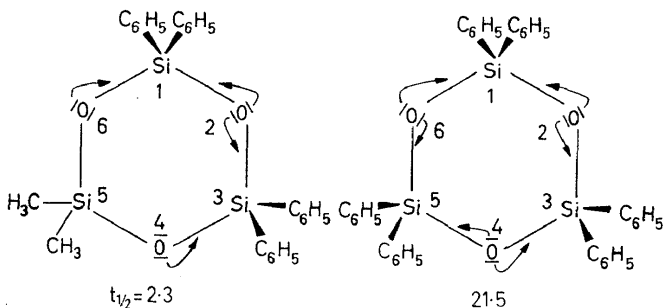

Figure 23

Figures 22 and 23. Reactivities of the series $D_3^{\text{Me}}-D_3^{\text{Ph}}$

As far as we know, these figures, for the first time, provide evidence of the enormous differences in reactivity, as they are qualitatively known from practical experience, and show to what great extent the behaviour of the siloxane linkage is dependent on substitution.

The investigations concerning the spreading behaviour were carried out together with Dr. Steinbach and Dr. Sucker, and the investigations concerning the acidolysis of the siloxane linkage together with Dr. Damm and Dr. Göltz.

References

- 1 W. Noll. *Angew. Chem.* **75**, 123 (1963).
- 2 H. W. Fox, P. W. Taylor, and W. A. Zisman. *Industr. Engng. Chem.* **39**, 401 (1947).
- 3 Chr. Sucker. *Kolloidzeitschrift* **190**, 146 (1963).
H. J. Rodewald. *Ber. Bunsenges. phys. Chem.* **69**, 89, (1965); *Kolloidzeitschrift* **202**, 164 (1965);
Chr. Sucker. *Ber. Bunsenges. phys. Chem.* **69**, 90 (1965); *Kolloidzeitschrift* **202**, 165 (1965).
- 4 W. Noll, H. Steinbach, and Chr. Sucker. *Ber. Bunsenges. phys. Chem.* **67**, 407 (1963).
- 5 W. Meskat and Chr. Sucker. Cf. *Kolloidzeitschrift* **204**, 94 (1965).
- 6 W. Noll, H. Steinbach and Chr. Sucker. *Kolloidzeitschrift* **204**, 94 (1965).
- 7 K. Damm, D. Göltz and W. Noll. *Angew. Chem.* **76**, 273 (1964).
- 8 K. Damm, D. Göltz and W. Noll. *Z. anorg. allg. Chem.* **340**, 1 (1965).