

# MICROWAVE SPECTROSCOPY IN THE REGION OF 4-0.4 MILLIMETRES†

W. GORDY

*Department of Physics, Duke University, Durham, North Carolina, U.S.A.*

The segment of the electromagnetic spectrum which is encompassed by wavelengths of 4-0.4 mm is a region of opportunity for the present-day spectroscopist. This entire span is now accessible to high-resolution, microwave-sweep spectroscopy, but the work of measuring the many spectral transitions of atoms, molecules, and crystals which fall in the region has only begun. In it, the spectral lines of most molecules are abundant enough to be found easily, but not so abundant that they cannot be well resolved. Absorption coefficients are generally so strong in the region that the chief problem in detecting spectra has been in finding an energy source of high spectral purity which can be made to sweep over the region where the absorption lines occur. Such a source has now been developed and proved operable to 0.43 mm wavelength.

## THE EXTENSION OF HIGH-RESOLUTION SPECTROSCOPY TO THE 4-0.4 MM REGION

Slowly, over a period of some 18 years, our laboratory has extended high-resolution microwave spectroscopy from the 5 mm region down to a wavelength of 0.43 or a frequency of 691,472 Mc/s, thus increasing the range of precise radiofrequency measurements by a factor of ten. Throughout the development we have used crystal harmonic generators driven by klystrons to provide the spectral energy and crystal diodes to detect it. We have persisted in the development of this method because it seemed to us an ideal one for submillimetre wave spectroscopy.

*Figures 1a and 1b* illustrate the chronological order of the progress of our laboratory in extending the range of high-resolution spectroscopy. Early in 1953 we reported a number of high-resolution measurements in the region of one to two millimetres<sup>1</sup>; in the latter part of that year we were able to reach into the submillimetre region<sup>2</sup> for the first time, overlapping the region studied with the lower resolution methods of infrared spectroscopy<sup>3</sup>. By 1958 we had reached a half-millimetre<sup>4</sup>, but not until 1964 were we able to go below a half-millimetre<sup>5</sup>. Display of the spectral lines on the cathode ray oscilloscope is convenient and beautiful, but it is a luxury which cannot be enjoyed near the borderline of detectability. An automatic pen-and-ink recorder makes possible a very slow sweep with a correspondingly narrow-banded receiver and hence the achievement of a

† This study was supported by the Air Force Office of Scientific Research of the U.S.A.

## MICROWAVE SPECTROSCOPY

sensitivity which is an order of magnitude greater than that which can be achieved in a display on a cathode ray scope. *Figures 1a* and *1b* show the order of progress by video and by pen-and-ink recorder.

The first overlapping of the radio and infrared regions, to the best of my knowledge, was accomplished by Nichols and Tear<sup>6</sup> in 1923 with a spark-gap generator and a radiometer detector. The spark-gap generator did not, however, prove practical either for radio or for high-resolution spectroscopy, and only dielectric dispersion measurements were made with it. Also, I wish to mention the detection with a Golay detector using harmonic energy from magnetrons in the region of 3–1.5 mm which was made by the Columbia University group<sup>7</sup> in 1949. They reported some fixed-frequency attenuation measurements on  $\text{DI}$  and  $\text{ND}_3$ , but, so far as I know, spectral lines were never measured with this method. More recently, an arc-discharge harmonic generator driven by a high-powered microwave oscillator has been used by Froome<sup>8</sup> to produce submillimetre radiation. I am unaware of any measurements of spectral lines which have been made with this generator, although I note in the abstracts of the present Congress that Knapp and Martin<sup>9</sup> report that line-shape measurements on  $\text{N}_2\text{O}$  have been made with a Froome-type harmonic generator. Before we started our millimetre-wave work, Beringer<sup>10</sup>, during World War II, made some measurements of  $\text{O}_2$  absorption in the 5-mm wave region. He did not, however, resolve the fine structure of this absorption.

While the developments described in the present paper were taking place, the artful “maser” appeared on the spectral scene. However, it skipped over the submillimetre region to the region of visible light, where it took the name “laser”. It has since been worked backward toward the microwave region and has been made by Gebbie *et al.*<sup>11</sup> to operate on a CN line at 0.377 mm. Thus there is still a gap to be closed between our present 0.43 limit and Gebbie’s 0.377 mm “laser” line, but there are gaps everywhere in the “laser” region because the laser is not exactly a tunable device. For this reason it does not provide a practical source for high-resolution absorption spectroscopy.

Although induced emission lines can be very sharp, the observation of each one is an unusual event, or so I understand, requiring special circumstances. It is not easy to observe spectral lines upside down in the millimetre and submillimetre wave region. Nevertheless, the laser will very probably be made eventually to operate at a number of fixed frequencies in the 4–0.4 mm wave region and should certainly serve important functions in this region. These functions are unlikely to be the same as those served by the high-resolution, frequency-sweep spectrometer described here.

A more complete treatment of the early history of the millimetre wave region is given in the article “Millimeter and Submillimeter Waves in Physics”<sup>12</sup>, and in other reviews<sup>13,14</sup>. These papers also contain summaries of many molecular constants and frequencies which have been measured in our laboratory for the 5–1 mm region. A non-technical description of the development is given in an article entitled “The Shortest Radio Waves”<sup>15</sup>.

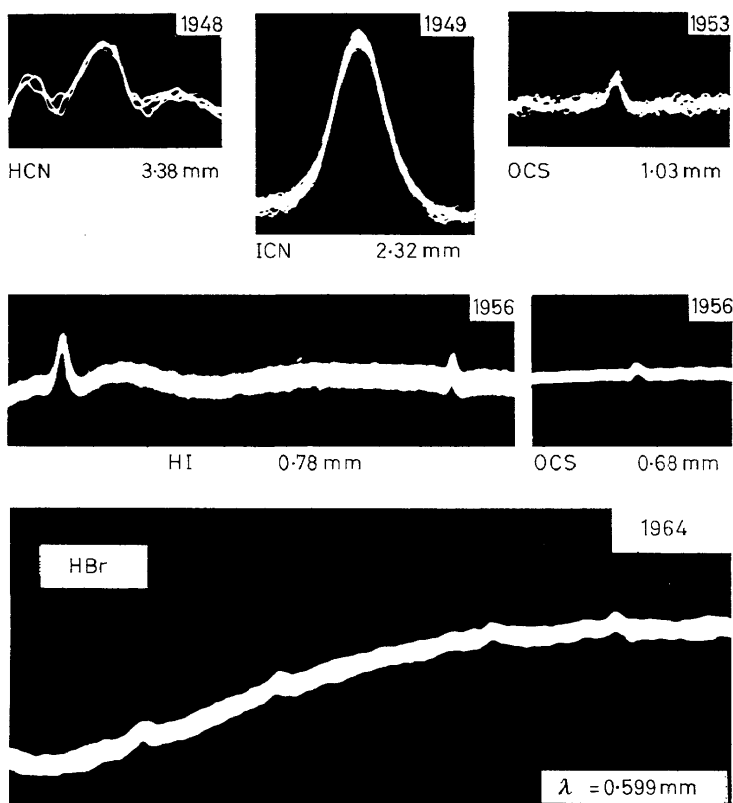

Figure 1(a). Chronological order of progress in display of spectral lines in the 4-0.4 mm wave region, observed in the Duke laboratory<sup>26,25,21,2,4,12,5</sup>

# MICROWAVE SPECTROSCOPY

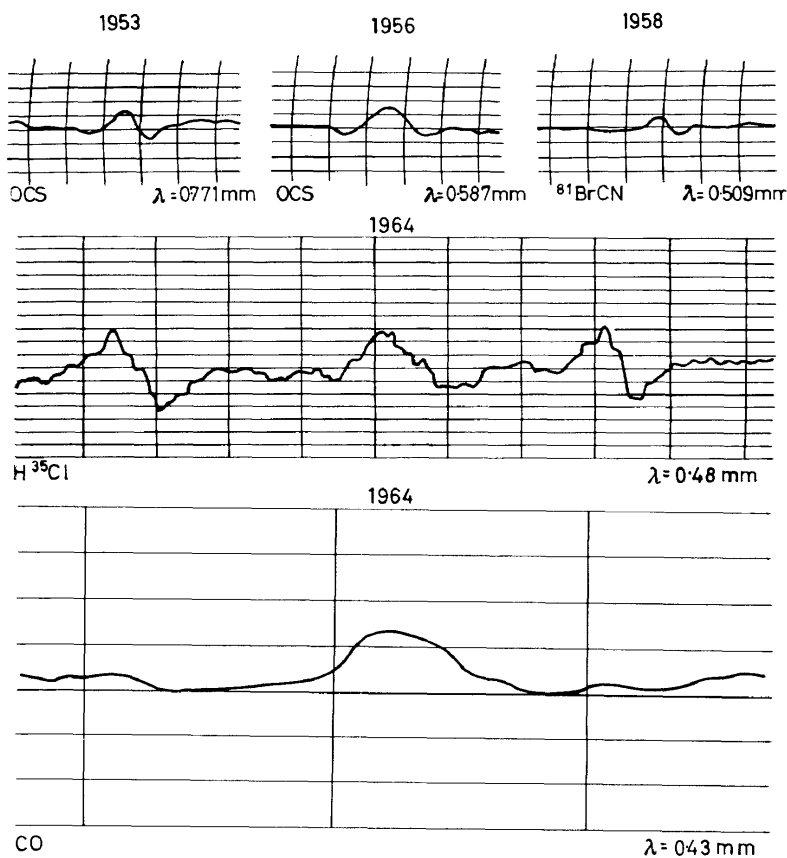

Figure 1(b). Chronological order of progress in display of spectral lines in the 4–0.4 mm wave region, observed in the Duke laboratory<sup>26,25,21,2,4,12,5</sup>

## INSTRUMENTS AND TECHNIQUES

The harmonic submillimetre wave source has an important advantage over primary submillimetre sources in that all frequency measurements can be made at the fundamental of the harmonic source. Standard frequency markers which are accurate to at least eight significant figures are not too difficult to provide for the centimetre or upper millimetre wave region where the driver klystron operates. In the United States they can

Table 1. Some submillimetre wave spectral frequencies measured at Duke

Molecule	Transition		Measured frequency (Mc/s)	Reference
	$J \rightarrow J'$	$F \rightarrow F'$		
N <sub>2</sub> O	11 → 12		301,442.38 ± 0.60	17
<sup>85</sup> RbF	23 → 24	( $v = 0$ )	301,607.21 ± 0.10	18
<sup>37</sup> ClCN	25 → 26		303,943.87 ± 0.65	17
CsF	27 → 28	( $v = 0$ )	308,009.147	18
Na <sup>35</sup> Cl	23 → 24	( $v = 1$ )	309,787.82	19
ND <sub>3</sub>	0 → 1	1 → 1	309,908.24	20
ND <sub>3</sub>	0 → 1	1 → 2	309,909.54	20
ND <sub>3</sub>	0 → 1	1 → 0	309,911.41	20
<sup>35</sup> ClCN	25 → 26		310,365.90 ± 0.65	17
Na <sup>35</sup> Cl	23 → 24	( $v = 0$ )	312,109.88	19
OC <sup>80</sup> Se	38 → 39		313,217.57 ± 0.65	17
D <sup>37</sup> Cl	0 → 1	3/2 → 3/2	322,339.09 ± 0.13	21
D <sup>37</sup> Cl	0 → 1	3/2 → 5/2	322,352.33 ± 0.13	21
D <sup>37</sup> Cl	0 → 1	3/2 → 1/2	322,362.94 ± 0.13	21
D <sup>35</sup> Cl	0 → 1	3/2 → 3/2	323,282.28 ± 0.13	21
D <sup>35</sup> Cl	0 → 1	3/2 → 5/2	323,299.17 ± 0.13	21
D <sup>35</sup> Cl	0 → 1	3/2 → 1/2	323,312.52 ± 0.13	21
Li <sup>35</sup> Cl	7 → 8	( $v = 2$ )	329,203.68	22
Li <sup>35</sup> Cl	7 → 8	( $v = 0$ )	336,771.14	22
<sup>12</sup> C <sup>16</sup> O	2 → 3		345,795.90 ± 0.09	23
H <sup>127</sup> I	0 → 1	5/2 → 5/2	385,000.11 ± 0.70	2
H <sup>127</sup> I	0 → 1	5/2 → 7/2	385,385.52 ± 0.70	2
H <sup>127</sup> I	0 → 1	5/2 → 3/2	385,548.80 ± 0.70	2
<sup>81</sup> Br- <sup>12</sup> C <sup>14</sup> N	47 → 48		392,907.0 ± 0.9	24
<sup>81</sup> Br- <sup>12</sup> C <sup>14</sup> N	51 → 52		425,575.9 ± 0.9	24
<sup>81</sup> Br- <sup>12</sup> C <sup>14</sup> N	55 → 56		458,226.2 ± 0.9	24
<sup>12</sup> C <sup>16</sup> O	3 → 4	3/2 → 1/2	461,040.68 ± 0.06	3
H <sup>81</sup> Br	0 → 1	3/2 → 1/2	500,406.68 ± 0.26	25
H <sup>81</sup> Br	0 → 1	3/2 → 5/2	500,497.48 ± 0.26	25
H <sup>79</sup> Br	0 → 1	3/2 → 1/2	500,540.66 ± 0.26	25
H <sup>81</sup> Br	0 → 1	3/2 → 3/2	500,608.64 ± 0.26	25
H <sup>79</sup> Br	0 → 1	3/2 → 5/2	500,648.90 ± 0.26	25
H <sup>79</sup> Br	0 → 1	3/2 → 3/2	500,782.04 ± 0.26	25
<sup>12</sup> C <sup>16</sup> O	4 → 5		576,267.75 ± 0.10	5
H <sup>35</sup> Cl	0 → 1	3/2 → 3/2	625,905.65 ± 0.52	5
H <sup>35</sup> Cl	0 → 1	3/2 → 5/2	625,922.74 ± 0.52	5
H <sup>35</sup> Cl	0 → 1	3/2 → 1/2	625,936.06 ± 0.52	5
<sup>12</sup> C <sup>16</sup> O	5 → 6		691,472.60 ± 0.60	5

be had through multiplication via a harmonic chain<sup>16</sup> of the megacycle or kilocycle frequencies broadcast by station WWV of the U.S. Bureau of Standards. Our harmonic submillimetre wave source thus extends the reach of radio frequency standards into the far-infrared region and makes possible the measurement of submillimetre wave frequencies in terms of the sidereal or solar time scale. It is of interest to note that the highest

## MICROWAVE SPECTROSCOPY

microwave frequency so far measured, 691,472 Mc/s, is 138,294 times the 5Mc/s standard frequency used to measure it. The measuring chain is getting decidedly long! Whenever a tunable, primary submillimetre wave source suitable for high resolution spectroscopy is developed, this harmonic chain will still be needed to measure its frequency.

In *Table 1* are listed some submillimetre wave spectral frequencies which have been measured in our laboratory. These can be used as secondary standards for experimenters who do not yet have a harmonic measuring chain.

Our first measurements in the 4–2 mm range<sup>21,25,26</sup> were made with the multiplier and detector crystals in coaxial mounts and with K-band klystrons (1.25 cm fundamental). The techniques and the many results achieved with them have been described<sup>13,16</sup> and need not be repeated here.

After unsuccessful efforts to extend measurement below 2 mm, we decided to reduce the size of the crystals and to mount them directly into the waveguide. To this project I assigned King, a new graduate student. This was a fortunate assignment. We obtained small crystals by breaking up some commercial 1N26 crystals. At the same time we designed a differential screw mechanism for critical adjustment of the pressure of the tungsten whisker on the crystal. We also set up equipment for sharpening electrologically the point of the whisker to the form which would give best results. *Figure 2* shows diagrams of the cross-sections of the crystal mounts; *Figure 3* shows the mounted crystal and the mounted cat whisker. *Figure 4* shows the multiplier and detector as component parts of a submillimetre wave spectrometer. Detailed descriptions of the designs and the experimental method may be found in the original papers<sup>1,27</sup>. These designs and procedures have remained basically the same although the waveguide sizes have been reduced for accommodation of klystron drivers of higher frequency and for the filtering out of lower harmonics. Also, electrical biasing<sup>4</sup> has been found to improve the performance in some adjustments. With these new designs, we were immediately able to measure lines to 1 mm wavelength and soon thereafter to extend the measurements into the submillimetre region<sup>1</sup>.

In 1956 we were fortunate to obtain some silicon crystals bombarded with high energy radiation by Ohl, of the Bell Telephone Laboratories. These crystals were found to improve the performance of the multiplier unit. The method of development of this crystal is described by Ohl, Budenstein, and Burrus<sup>28</sup>. We are greatly indebted to the Bell Laboratories for supplying us with these crystals.

Another factor which has contributed to the performance of our multiplier unit is the improvement of millimetre-wave klystrons by various commercial concerns. The first submillimetre-wave measurements, to 0.77 mm, were achieved with Raytheon klystrons operating in the 1.25 cm wave range. The extension from 0.77 mm to 0.50 mm wavelength was achieved with the British EMI klystrons operating in the range of 8 mm wavelength. The extension from 0.50 mm to 0.43 mm was achieved with the Japanese OKI klystrons operating in the 5 mm region. With klystrons and other primary oscillators now developed to operate in the shorter

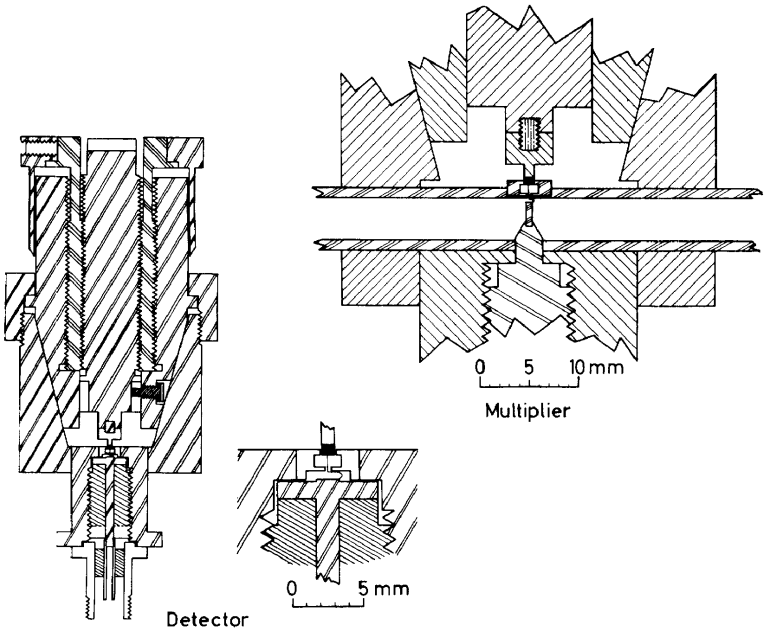
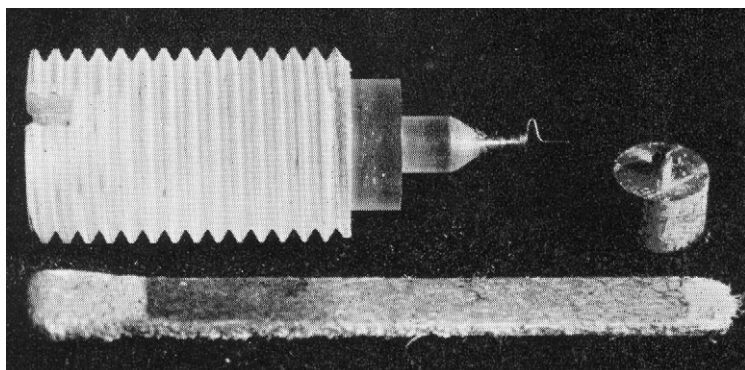
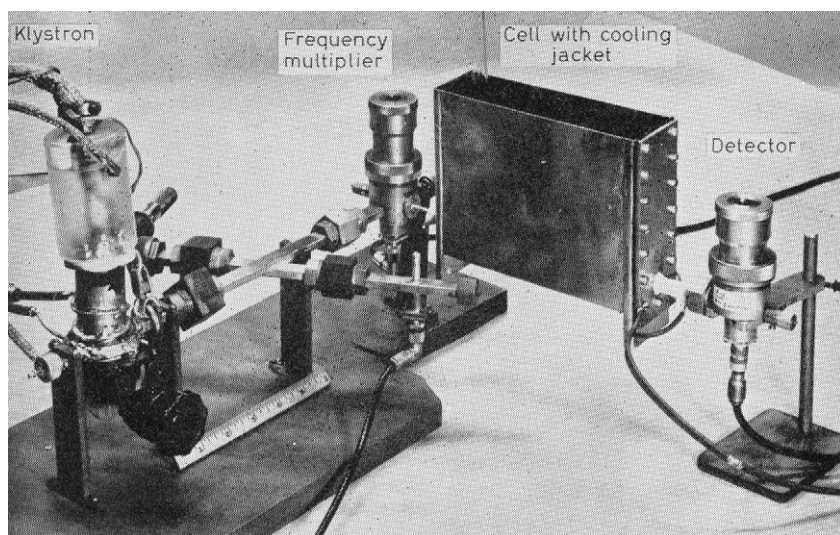

Figure 2. Cross-section diagrams of the Duke harmonic generator and detector for the 4-0.4 mm region. The differential screw mechanism for adjusting the pressure of the whisker on the crystal shown for the detector in the diagram to the left is identical for the multiplier unit. (After King and Gordy<sup>27</sup>)

## MICROWAVE SPECTROSCOPY



*Figure 3.* Photograph of mounted tungsten whisker and mounted silicon crystal for harmonic multiplier unit. The match included for size perspective is about 3 mm in width



*Figure 4.* Photograph of the microwave components of the first high resolution spectrometer to operate in the submillimetre wave region<sup>2</sup>. Cross-sections of the detecting unit (right) and the frequency multiplying unit (centre) are shown in *Figure 2*

(Reproduced by courtesy of the Editor of *The Physical Review*)



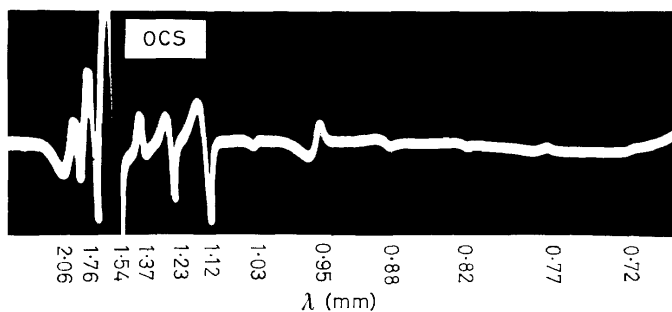

Figure 5 (a). Display of twelve different rotational lines of OCS on a single cathode ray sweep. The lines, which vary in frequency from 146 Gc/s to 416 Gc/s were obtained with the sixth to seventeenth harmonics of a 1.23 cm wave source. Because of centrifugal distortion, the rotational lines, unlike the klystron harmonics, are not exactly integral multiples of the fundamental. For this reason they appear at different positions on the CRO sweep which is synchronized with the klystron sweep

# MICROWAVE SPECTROSCOPY

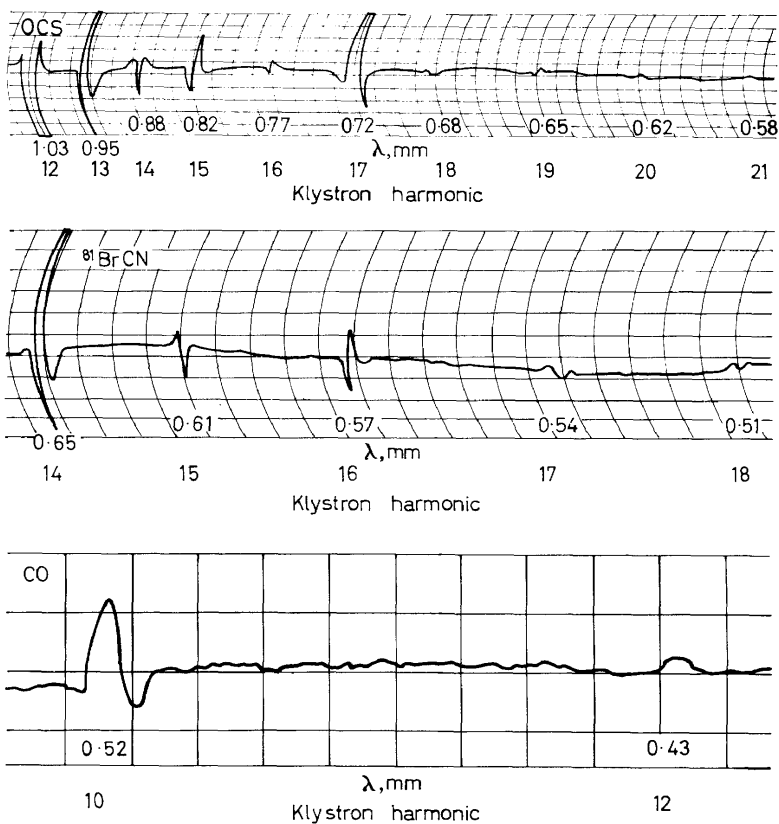

Figure 5 (b). Recordings showing submillimetre wave rotational lines from 1.0–0.43 mm wavelengths obtained with different harmonics, as described in (a). The curves for OCS and BrCN are after Cowan<sup>29</sup> and that for CO after Jones<sup>30</sup>. The tracings were obtained with a spectrometer like that shown in Figure 4 and are described by King and Gordy<sup>27</sup>

millimetre wave region, we hope to extend the workable submillimetre range to 0.3 mm, or below.

Figures 5a and 5b illustrate the remarkably broad-banded coverage of the harmonic generators and detectors. The top tracing of Figure 5b shows spectral lines from 1.03 mm to 0.587 mm taken by different harmonics of the klystron power. The other two tracings show an extension on down to 0.43 mm. To understand these tracings it is necessary to realize that the different harmonics of the klystrons are exact integral multiples, whereas the rotational frequencies of the linear molecules are almost integral multiples, but not exactly so. The departure by the molecular frequencies from the exact harmonic relationship is caused by centrifugal distortion. These effects of centrifugal distortion can be easily and accurately measured from such traces. By twiddling the various tuning knobs, an operator can alter significantly the relative strengths of the lines "seen" with the different harmonics, although the device is so broad-banded that one finds it actually difficult to quench some of the lines while others are seen.

Figure 1 illustrates the advantage of the harmonic generator in increasing the frequency span of the electronic sweep. The two hyperfine components shown for HI are 163 Mc/s apart, whereas the entire klystron mode covers only 60 Mc/s, approximately. Since these lines were observed with the sixteenth harmonic, it was necessary to sweep the driving klystron over only 10 Mc/s, approximately, to cover both components. The lines shown for HBr are four of the six hyperfine components for the same rotational transition,  $J = 0 \rightarrow 1$ , of  $\text{H}^{79}\text{Br}$  and  $\text{H}^{81}\text{Br}$  observed with the eighth harmonic of the klystron. The outside components are separated by 150 Mc/s. Thus, to cover these four lines, it is necessary to sweep the klystron only 19 Mc/s.

From Figure 1, it is obvious that one can easily search many segments of the spectrum simultaneously with such broad-banded harmonic generators and detectors as these. It is also obvious that one can search an enormous region of the spectrum with the same spectrometer, even with a single primary oscillator. This system makes search for unknown lines not only rapid but relatively inexpensive. When different segments of the spectrum are searched simultaneously, care must be used in the identification of the particular harmonic with which the unknown line is found. Any uncertainty about identification can be resolved if the klystron is tuned so that the same line is detected with a different harmonic. The ratio of the two klystron frequencies determines the harmonics involved. We call this the cross-fire method of harmonic identification.

Identification of the different harmonics can also be achieved by use of a superheterodyne receiver for observation of the beat notes between the corresponding harmonics of two harmonic generators which have slightly different fundamentals. When the frequency difference of the two fundamental sources is held constant, the beat frequency increases with the harmonic number. Thus, if the recording instrument is synchronized with the frequency sweep of the receiver, the beat notes between the different harmonics can be observed and displayed separately. If the receiver tuning and one source are maintained at fixed frequencies while the other source has its frequency swept, the different harmonics can be displayed separately

## MICROWAVE SPECTROSCOPY

 Table 2. Spectroscopic constants of hydrogen halides from submillimetric wave spectroscopy<sup>4,31</sup>

Molecule	$\nu_0$ (Mc/s)	$\lambda_0$ (mm)	$eQq$ (hal.) (Mc/s)	$C_I$ (hal.) (Mc/s)	$B_0$ (Mc/s)	$B_e$ (Mc/s)	$r_0$ (Å)	$r_e$ (Å)
H <sup>35</sup> Cl	625,919.24 ± 0.52	0.48	-68.0 ± 2.8	0	312,991.30 ± 0.26	317,587	1.28387	1.27455
H <sup>79</sup> Br	500,675.24 ± 0.26	0.599	535.4 ± 1.4	0.29 ± 0.20	250,360.78 ± 0.13	253,790	1.42439	1.41460
H <sup>81</sup> Br	500,519.41 ± 0.26	0.599	447.9 ± 1.4	0.31 ± 0.20	250,282.88 ± 0.13	253,710	1.42402	1.41460
H <sup>127</sup> I	385,293.27 ± 0.70	0.778	-1831.0 ± 3.0	0.26 ± 0.20	192,658.8 ± 0.5	195,200	1.61972	1.60914

as a function of the sweep of the source. The receiver band-width must in each case be sufficiently narrow for discrimination between the different beat notes.

## HYDROGEN HALIDES AND THE VELOCITY OF LIGHT

Millimetre and submillimetre wave spectra of hydrogen<sup>4,31</sup>, deuterium<sup>32</sup>, and tritium<sup>33</sup> halides—except the fluorides—have now been measured. Submillimetre wave frequencies measured for the hydrogen halides are listed in *Table 1*, and the spectra are shown in *Figure 1*. The first rotational line of HF falls at 0.24 mm, outside our present submillimetre wave coverage. Although the  $J = 0 \rightarrow 1$  transitions of DF and TF fall within our reach, we have not had time to measure them.

*Table 2* has listings of molecular constants which have been derived from submillimetre wave spectra of the hydrogen halides. Second order distortion constants  $D$  and  $\alpha$  from infrared data have been used in these evaluations. The stretching effects for the high rotational states of the hydrogen halides observed in the infrared region are so large that accurate values of the centrifugal distortion constants  $D$  can be obtained. Therefore infrared  $D_0$  values with our  $\nu_0$  values yield very precise  $B_0$  values.

Some years before our measurement of  $H^{35}Cl$ , Rank *et al.*<sup>34</sup> evaluated with great accuracy the  $B_0$  value of  $H^{35}Cl$  in wavelength units by measuring its near-infrared spectra with a precision grating spectrometer. The value they obtained with the stated limits of error is  $B_0 = 10.440254 \pm 0.000010 \text{ cm}^{-1}$ . The limits of error are comparable to those for the best present values of the velocity of light. Since our measurement of  $B_0$  is in frequency units, with limits of error still smaller (see *Table 2*), it is possible to obtain a new and better evaluation of the velocity of light from the ratio of these two  $B_0$  values. The resulting value for  $c$  given in *Table 3* is seen to be in agreement with, and of comparable accuracy to, the best values of  $c$  obtained

*Table 3.* Comparison of the best values of the velocity of light

Source	Method	$c$ (km/s)
Froome <sup>35</sup>	Microwave interferometer	299,792.5 $\pm$ 0.1
Bergstrand <sup>36</sup>	Geodimeter	299,792.9 $\pm$ 0.2
Dumond and Cohn <sup>37</sup>	Weighted average	299,793.0 $\pm$ 0.3
Rank <sup>34</sup> (infrared)	Spectroscopy ( $H^{35}Cl$ )	299,792.8 $\pm$ 0.4
Jones and Gordy <sup>5</sup> (submillimetre-wave)		

with more direct methods of measurement. This is a tribute to Rank's measurement, which, to the best of my knowledge, is one of the most precise ever made with an infrared grating spectrometer.

## PRECISION STARK SPECTROMETER

The region of 4–1 mm wavelength appears to be nearly the optimum one for most Stark effect measurements. At these wavelengths, the Stark

## MICROWAVE SPECTROSCOPY

splittings are still easy to produce with fields of reasonable strength for many spectral lines; and, in this region, high-precision, parallel-plate Stark cells for observation of both  $\pi$  and  $\sigma$  components become most practical. In 1948 I first proposed<sup>26</sup> that a parallel-plate cell should be effective for measurement of the Stark effect in microwave spectroscopy. Shortly afterwards, we constructed such a cell for operation in the centimetre region but found that sensitivity was not sufficiently good in a cell of reasonable size. We then began the development of a parallel-plate cell for the 4-1 mm region. With our first working model for this region, one of my students, Fugii, made Stark measurements<sup>38</sup> on the  $\Delta M = 0$  Stark components of HCN in 1954. These results were repeated later with greater accuracy by another student, Bhattacharya<sup>39,40</sup> who used this same cell to observe  $\Delta M = \pm 1$  components; for this observation the static electric field must be imposed at right angles to the electric component of the microwave radiation. This is not possible with a conventional strip-in-the-waveguide cell<sup>41</sup> but with the parallel-plate cell it can easily be achieved when the source and the detector units are arranged so that an electric component of the radiation is parallel to the plates (*Figure 6*). For this arrangement, the horns must be properly designed to transmit the desired mode, and the separation between the plates must be greater than  $\lambda/2$ .

To increase the precision of such cells, we now use silver-coated plate glass separated by optically ground quartz spacers. To increase the effective focus, we use Teflon lenses installed in the flat horns. The d.c. voltage applied across the horns we measure with a precision potentiometer.

*Figures 7 and 8* illustrate the type of resolution which is obtainable with this parallel-plate cell. *Table 4* presents some dipole moments which have

*Table 4.* Dipole moments measured with parallel-plate, millimetre-wave Stark spectrometer

<i>Molecule</i>	<i>Transition</i>	<i>Moment (Debye units)</i>	<i>Reference</i>
HCN	$J = 0 \rightarrow 1$	$2.986 \pm 0.004$	33
HN <sub>3</sub>	$J = 3 \rightarrow 4$	$\mu_a = 0.8368 \pm 0.0013$	42
	$K = 1$	$\mu_a = 0.8247 \pm 0.0005$	42
HNCO	$J = 3 \rightarrow 4$	$\mu_a = 1.613 \pm 0.002$	42
	$K = 1$	$\mu_a = 1.575 \pm 0.001$	42
	$K = 2$	$\mu_a = 1.540 \pm 0.001$	42
	$K = 3$	$\mu_a = 1.500 \pm 0.001$	42
	$K = 2$	$\mu_a = 1.602 \pm 0.002$	42
DNCO	$J = 3 \rightarrow 4$	$\mu_a = 1.580 \pm 0.001$	42
	$K = 2$	$\mu_a = 1.580 \pm 0.001$	42
CH <sub>3</sub> F	$J = 1 \rightarrow 2$	$1.8572 \pm 0.0010$	43, 44
CD <sub>3</sub> F	$J = 1 \rightarrow 2$	$1.8682 \pm 0.0010$	44
CH <sub>3</sub> CN	$J = 4 \rightarrow 5$	$3.913 \pm 0.0020$	44
CD <sub>3</sub> CN	$J = 5 \rightarrow 6$	$3.919 \pm 0.0025$	44

been measured with it operating in the 4-1 mm wave region. The accuracy of these dipole moments is an order of magnitude greater than that generally quoted for measurements with Stark cells of conventional waveguide. These dipole moments demonstrate that effects of isotopic substitution and of centrifugal distortion can easily be measured with such a Stark spectrometer.

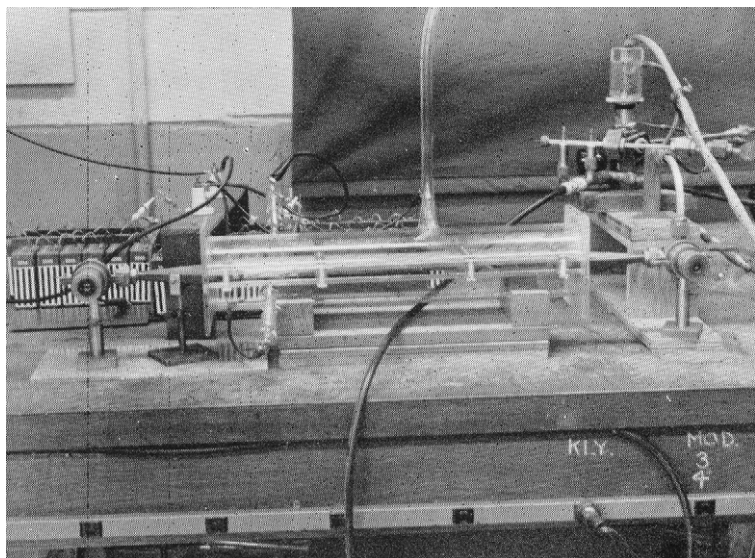

Figure 6. Parallel-plate, millimetre-wave Stark spectrometer arranged for observation of  $\Delta M = \pm 1$  components. For observation of  $\Delta M = 0$  components, the harmonic source and detector are rotated 90 degrees

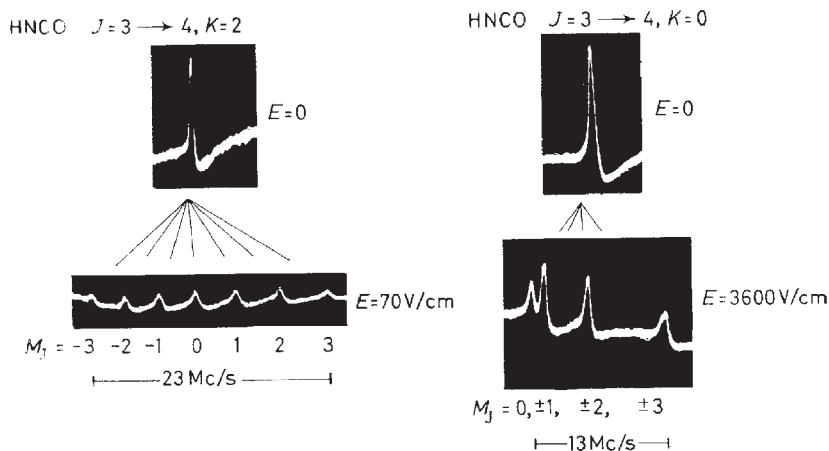

Figure 7. First and second order  $\Delta M = 0$  Stark components for an asymmetric rotor HNC0, observed with a parallel-plate Stark cell operating in the 3.4 mm wave region (after White<sup>42</sup>)

MICROWAVE SPECTROSCOPY

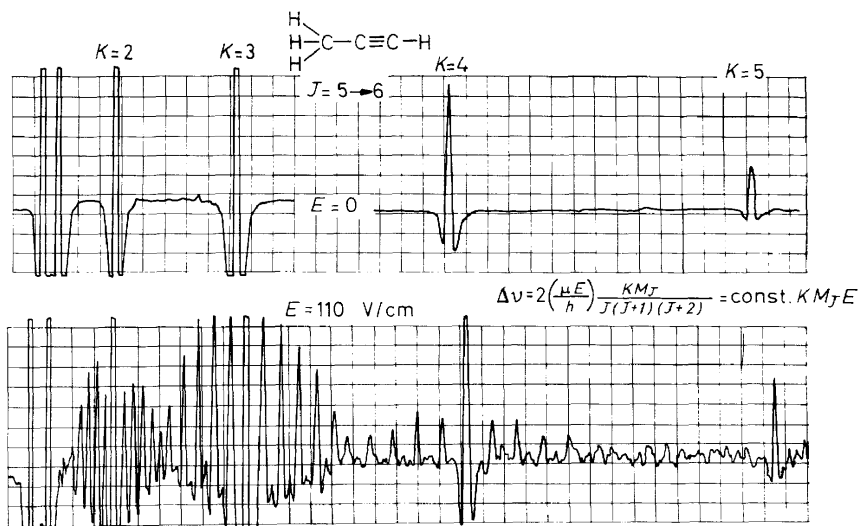

Figure 8. Illustration of the first-order Stark splitting of a symmetric-top molecule observed with a parallel-plate Stark cell operating in the 2.9 mm wave region (after Steiner<sup>14</sup>)



## SPECTROSCOPY OF UNSTABLE MOLECULAR SPECIES

In the design of a "free space" absorption cell<sup>45,46</sup> for the study of free radicals and other unstable species, we have taken advantage of the ease with which short millimetre waves can be focused. The focusing is accomplished through a combination of horns and lenses. Horns, lenses, cells, and other millimetre wave components are shown in *Figure 9a*. *Figure 9b* is a diagram of the entire spectrometer. The sample is contained in a cylindrical glass cell which is placed in the path of the focused radiation. Connected to the glass cell and immediately below, is an arrangement for the production of gaseous free radicals with a glow discharge. This spectrometer has been used for study of carbon monosulphide<sup>45</sup>, sulphur monoxide<sup>46</sup>, hydrogen persulphide<sup>47</sup>, and another unstable species<sup>48</sup> tentatively identified as SH. More than 100 lines have been measured<sup>47</sup> for H<sub>2</sub>S<sub>2</sub> in the 4–1 mm wave region by M. Winnewisser and G. Winnewisser. For this relatively unstable gas, the lifetime in the glass cell is found to be a few hours.

First order Stark or Zeeman splitting can be observed with Stark plates or magnetic coils placed outside the glass envelope, although for observation of the second order Stark effect it is necessary to put the Stark plates

Table 5. Derived spectroscopic constants<sup>††</sup> and observed  $\lambda$ -doublet frequencies<sup>‡</sup> of SO

Transition	Observed frequency (Mc/s)	Calculated frequency (Mc/s)
$N = 1 \rightarrow 2$	$99,299.85 \pm 0.50$	99,298.82
$J = 2 \rightarrow 3$		
$N = 1 \rightarrow 2$	$86,093.94 \pm 0.50$	86,090.50
$J = 1 \rightarrow 2$		
$N = 2 \rightarrow 3$	$138,178.60 \pm 0.50$	138,179.65
$J = 3 \rightarrow 4$		
$N = 2 \rightarrow 3$	$109,252.22 \pm 0.50$	109,251.13
$J = 1 \rightarrow 2$		
$N = 3 \rightarrow 4$	$172,181.46 \pm 0.50$	172,181.12
$J = 3 \rightarrow 4$		
$N = 3 \rightarrow 4$	$158,971.80 \pm 0.50$	158,972.86
$J = 2 \rightarrow 3$		

<sup>†</sup> These constants are for the radical in the <sup>3</sup>Σ electronic ground state. The errors reported are based on the uncertainties in the frequency measurements and on uncertainties produced by neglect of centrifugal distortion effects.

<sup>‡</sup> From Winnewisser, Sastry, Cook and Gordy<sup>48</sup>. The molecules are in the ground vibrational state.

inside, as shown in *Figure 6*. Further details about these procedures can be obtained from the original publication<sup>45,46</sup>.

The "free-space" spectrometer is easily adapted to magnetic modulation with phase-sensitive detection and automatic recording. *Figure 10* shows recordings of two SO transitions thus obtained with 4 kc/s magnetic modulation by M. Winnewisser. One of these represents a rotational transition,

## MICROWAVE SPECTROSCOPY

essentially an electric dipole transition. The very weak line is an electronic spin transition which is induced primarily by the magnetic dipole moment. In *Figure 11*, an  $\text{H}_2\text{S}$  line observed at  $\lambda = 0.81$  mm (369,128 Mc/s) demonstrates that the focusing Teflon lenses are not prohibitive lossy for sub-millimetre wave measurements.

In *Table 5* are listed some frequencies of SO in  $^3\Sigma$  electronic ground states which have been measured with this "free-space" spectrometer operating in the 4-1 mm region. In this table are also listed the molecular constants which are derived from them.

Using focusing horns and Teflon lenses like those shown in *Figure 9*, we have also constructed a "free-space" cell with a metallic enclosure. This

*Table 6.* Comparison of calculated and observed frequencies of  $\text{CsF}^{18}$

$J \rightarrow J'$	$v$	<i>Measured frequency (Mc/s)</i>	<i>Calculated frequency (Mc/s)</i>	<i>Difference (Mc/s)</i>
$8 \rightarrow 9$	0	99,156.072	99,156.071	-0.001
$9 \rightarrow 10$	0	110,168.823	110,168.814	-0.009
$12 \rightarrow 13$	0	143,197.757	143,197.748	-0.009
$15 \rightarrow 16$	0	176,209.641	176,209.691	+0.050
$16 \rightarrow 17$	0	187,209.277	187,209.219	-0.058
$18 \rightarrow 19$	0	209,200.725	209,200.723	-0.002
$19 \rightarrow 20$	0	220,192.348	220,192.408	+0.060
$20 \rightarrow 21$	0	231,181.211	231,181.190	-0.021
$27 \rightarrow 28$	0	308,009.147	308,009.138	-0.009
$8 \rightarrow 9$	1	98,522.943	98,522.952	+0.009
$9 \rightarrow 10$	1	109,465.332	109,465.341	+0.009
$12 \rightarrow 13$	1	142,283.228	142,283.200	-0.028
$16 \rightarrow 17$	1	186,013.252	186,013.195	-0.057
$20 \rightarrow 21$	1	229,703.597	229,703.630	+0.033
$8 \rightarrow 9$	2	97,891.179	97,891.197	+0.018
$9 \rightarrow 10$	2	108,763.371	108,763.384	+0.013
$12 \rightarrow 13$	2	141,370.596	141,370.622	+0.026
$16 \rightarrow 17$	2	184,819.762	184,819.748	-0.014
$8 \rightarrow 9$	3	97,260.822	97,260.806	-0.016

spectrometer, which can be used for study of unstable species at higher temperatures, is similar to the high-temperature, molecular-beam spectrometer described in the next section. With it, rotational lines of the unstable species AlF have been measured in the 4-1 mm region by Pearson, a graduate student.

### **HIGH-TEMPERATURE, MOLECULAR-BEAM SPECTROMETER**

Because of the increase in intensity of rotational lines with frequency, approximately as the cube of the frequency for diatomic or linear molecules, it becomes possible in the 4-1 mm region to detect the absorption spectra of collimated, high-temperature, molecular beams which are simply sprayed across the radiation path, as indicated in *Figure 12*. Such molecular beams were first detected by Garrison and Gordy<sup>49</sup> in 1957. *Figure 13* shows cathode ray scope displays of a KCl line which they obtained in the 3 mm region. This line is only 60 kc/s in width, but it is distorted somewhat by the receiver, for increase of the signal-to-noise ratio. *Figure*

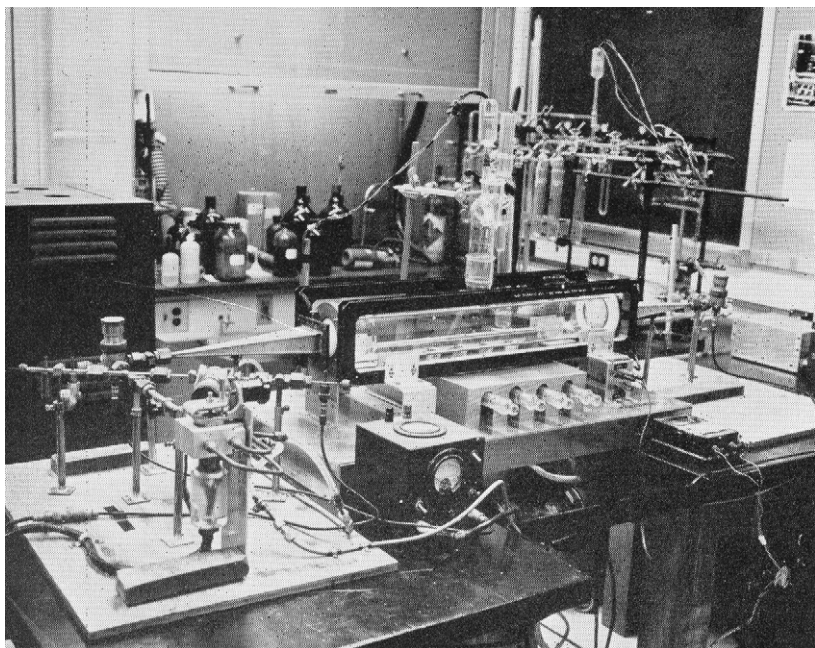

*Figure 9 (a).* "Free-space" millimetre and submillimetre wave spectrometer for observation of unstable molecular species. The radiation is focused by a combination of horns and Teflon lenses

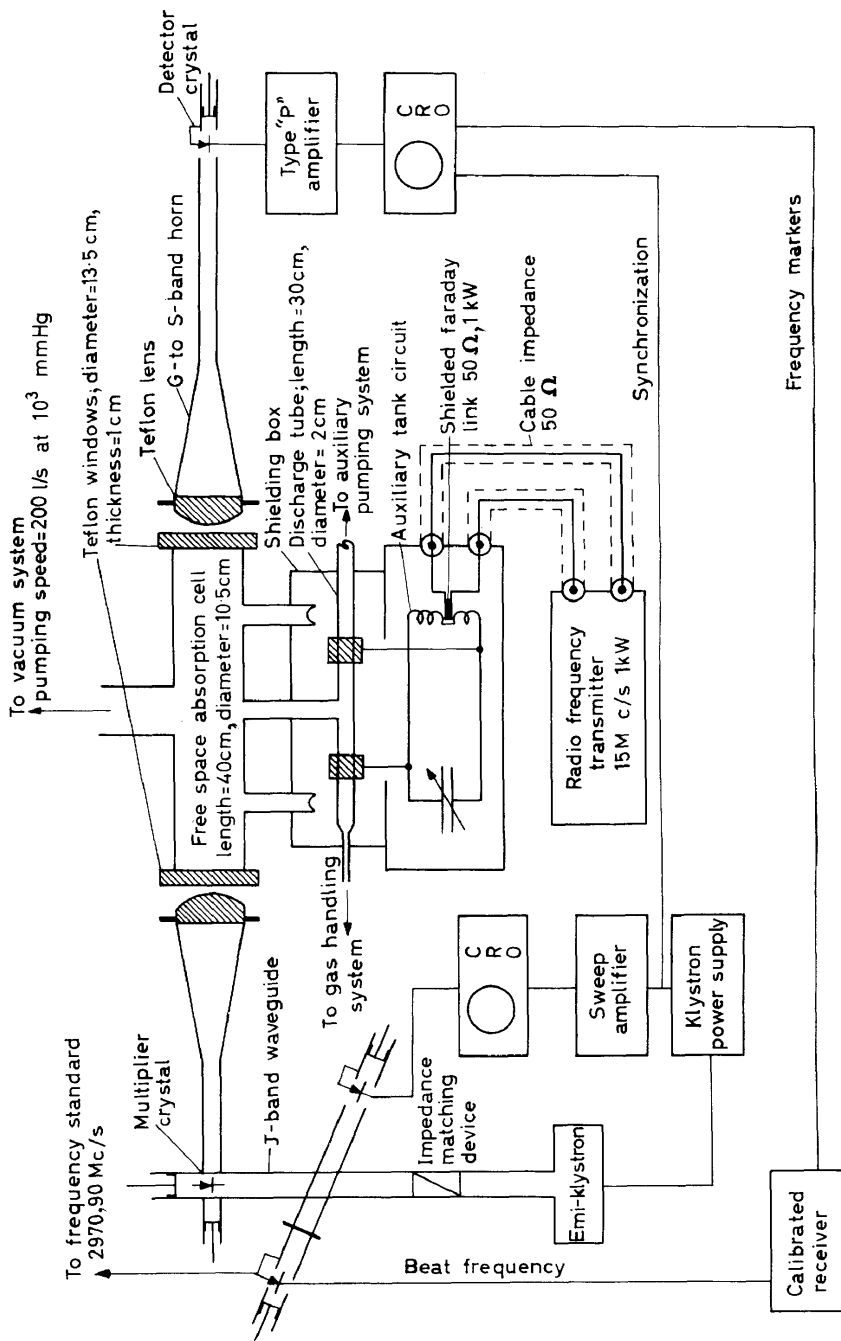

Figure 9(b). Diagram of the spectrometer (given in Figure 9(a)) for observation of unstable molecular species (after Kewley et al.<sup>45</sup>)

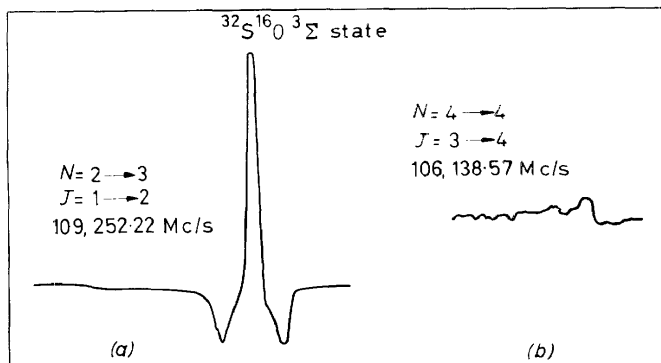

Figure 10. Recording, i.e. the line as produced by a pen-and-ink recorder of a rotational transition at 109,252.22 Mc/s (a) and an electronic spin transition at 106,138.57 Mc/s (b) of SO in the  $^3\Sigma$  ground state. These lines were observed by M. Winnewisser with the spectrometer of Figure 9 employing Zeeman modulation of the lines with a phase lock-in amplifier

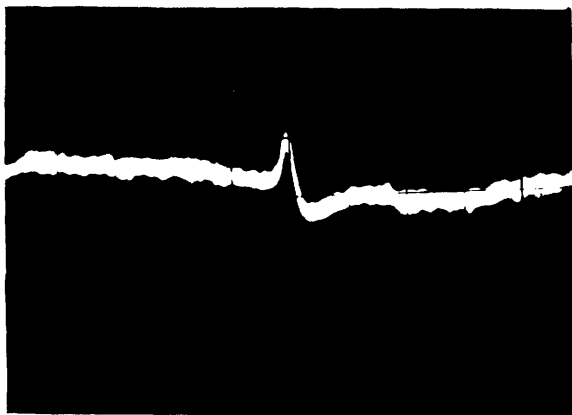

Figure 11. Cathode ray display of the  $3_{-1} \rightarrow 3_1$  line of  $\text{H}_2\text{S}$  at 369,128 Mc/s demonstrating the submillimetre wave operability of the "free space" spectrometer of Figure 9 ( $\lambda = 0.81 \text{ mm}$ )

# MICROWAVE SPECTROSCOPY

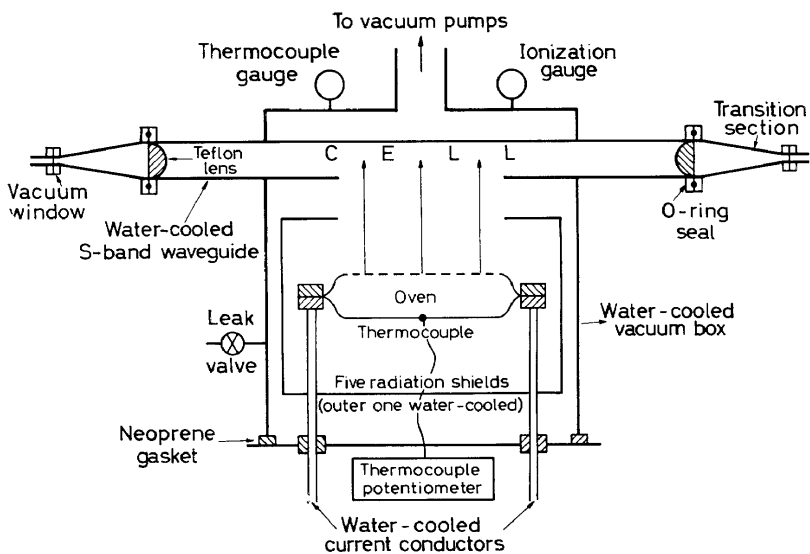

Figure 12. Diagram of the Duke high-temperature, molecular-beam absorption spectrometer for operation in the millimetre and submillimetre wave region. (After Veazey and Gordy<sup>18</sup>)

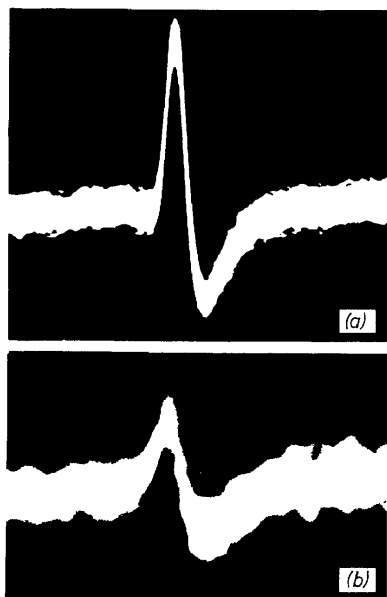

Figure 13. Cathode ray display of (a)  $K^{35}Cl$  and (b)  $NaF$  lines observed with a spectrometer like that of Figure 12. (a)  $J = 12 \rightarrow 13$ ,  $\lambda = 3.00$  mm; (b)  $J = 5 \rightarrow 6$ ,  $\lambda = 1.92$  mm. (After Garrison and Gordy<sup>49</sup> and Veazey and Gordy<sup>18</sup>)

(Reproduced by courtesy of the Editor of *The Physical Review*)

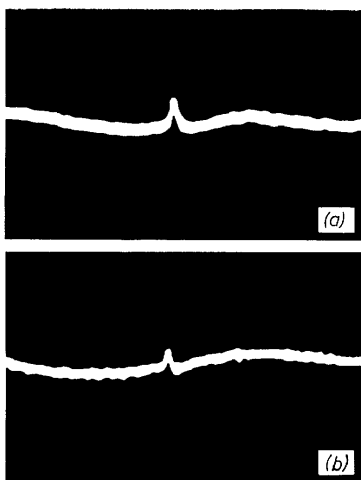

Figure 14.  $CsF$  rotational lines for excited vibrational states (a)  $v = 1$  and (b)  $v = 2$  at frequencies of 142,283 Mc/s and 141,370 Mc/s, respectively, as observed with the spectrometer of Figure 12. (After Veazey and Gordy<sup>18</sup>)

(Reproduced by courtesy of the Editor of *The Physical Review*)

## MICROWAVE SPECTROSCOPY

14 shows rotational lines of CsF in excited vibrational states. The highest molecular-beam spectral frequency so far observed with the spectrometer is 336771.14 Mc/s, or  $\lambda = 0.89$  mm (see *Table I*). Because of the losses in the large focusing horns, in the thick lenses, and in the absorption cell it is not possible to reach as far into the submillitre wave region with this spectrometer as with one employing a short waveguide cell. However, we have plans for modification of the spectrometer which should reduce the submillimetre wave losses in it.

The strong spectral absorption lines which make possible high-temperature molecular-beam spectroscopy are not the only reasons for making such measurements in the shorter millimetre region. High-frequency measurements are necessary if centrifugal distortion constants are to be obtained for such heavy molecules as the alkali halides for which distortion constants have not proved measurable with optical spectroscopy. Although the  $J = 0 \rightarrow 1$  transitions of a few of the alkali halides have been measured to high precision with molecular-beam resonance techniques, the measurements could not give comparably accurate values of  $B_0$  and other rotational constants because the effects of centrifugal distortion were not measured.

*Table 7.* Some rotational constants obtained from millimetre-wave, molecular-beam spectroscopy

<i>Molecule</i>	$B_e(\text{Mc/s})$	$\alpha_e(\text{Mc/s})$	$r_e(\text{\AA})$	<i>Reference</i>
<sup>7</sup> LiF	40,331.030 ± 0.017	608.093 ± 0.021	1.5639 ± 0.00004	22
NaF	13,098.042 ± 0.014	136.618 ± 0.014	1.926032 ± 0.000037	18
KF	8392.349 ± 0.009	69.999 ± 0.008	2.171554 ± 0.000042	18
<sup>85</sup> RbF	6315.576 ± 0.006	45.652 ± 0.004	2.270435 ± 0.000043	18
<sup>87</sup> RbF	6288.957 ± 0.007	45.338 ± 0.004	2.270450 ± 0.000044	18
CsF	5527.266 ± 0.002	35.247 ± 0.002	2.345462 ± 0.000045	18
<sup>7</sup> Li <sup>35</sup> Cl	21,181.286 ± 0.011	240.144 ± 0.014	2.02075 ± 0.00005	22
Na <sup>35</sup> Cl	6537.406 ± 0.006	48.711 ± 0.009	2.360898 ± 0.000046	19
Na <sup>37</sup> Cl	6397.320 ± 0.006	47.151 ± 0.009	2.360898 ± 0.000046	19
K <sup>35</sup> Cl	3856.385 ± 0.009	23.681 ± 0.013	2.666772 ± 0.000054	19
K <sup>37</sup> Cl	3746.592 ± 0.009	22.678 ± 0.013	2.666771 ± 0.000054	19
<sup>85</sup> Rb <sup>35</sup> Cl	2627.397 ± 0.004	13.599 ± 0.004	2.786865 ± 0.000055	19
<sup>87</sup> Rb <sup>35</sup> Cl	2609.776 ± 0.004	13.458 ± 0.006	2.786869 ± 0.000055	19
<sup>85</sup> Rb <sup>37</sup> Cl	2526.860 ± 0.004	12.826 ± 0.005	2.786864 ± 0.000055	19
Cs <sup>35</sup> Cl	2161.247 ± 0.002	10.119 ± 0.002	2.906411 ± 0.000057	19
Cs <sup>37</sup> Cl	2068.814 ± 0.003	9.476 ± 0.003	2.906408 ± 0.000057	19
<sup>7</sup> Li <sup>79</sup> Br	16,650.179 ± 0.10		2.17042 ± 0.00004	50
<sup>7</sup> Li <sup>81</sup> Br	16,616.622 ± 0.13		2.17042 ± 0.00004	50
Na <sup>79</sup> Br	4534.4658 ± 0.0072	28.2091 ± 0.0038	2.50201 ± 0.00004	50
Na <sup>81</sup> Br	4509.2009 ± 0.012	27.9688 ± 0.0066	2.50201 ± 0.00004	50
K <sup>79</sup> Br	2434.945 ± 0.002		2.82075 ± 0.00005	50
K <sup>81</sup> Br	2415.073 ± 0.002		2.82075 ± 0.00005	50
<sup>85</sup> Rb <sup>79</sup> Br	1424.8522 ± 0.0016	5.5760 ± 0.0012	2.94471 ± 0.00005	50
<sup>87</sup> Rb <sup>79</sup> Br	1409.080 ± 0.015		2.94471 ± 0.00005	50
<sup>85</sup> Rb <sup>81</sup> Br	1406.6192 ± 0.0043	5.4667 ± 0.0043	2.94471 ± 0.00005	50
Cs <sup>79</sup> Br	1081.3333 ± 0.0022	3.72052 ± 0.00040	3.07221 ± 0.00005	50
Cs <sup>81</sup> Br	1064.5819 ± 0.0042	3.63152 ± 0.0036	3.07221 ± 0.00005	50
<sup>7</sup> LiI	13,286.15 ± 0.10		2.39191 ± 0.00004	50
NaI	3531.7187 ± 0.0072	19.4198 ± 0.0052	2.71143 ± 0.00004	50
KI	1824.9778 ± 0.0014	8.0272 ± 0.0015	3.04781 ± 0.00005	50
<sup>85</sup> RbI	984.3062 ± 0.0024	3.28156 ± 0.0017	3.17684 ± 0.00005	50
<sup>87</sup> RbI	970.7519 ± 0.0040	3.2133 ± 0.0037	3.17684 ± 0.00005	50
CsI	708.32904 ± 0.00090	2.04638 ± 0.00057	3.31515 ± 0.00006	50



Table 8. Vibrational constants obtained from millimetre-wave, molecular-beam spectroscopy

<i>Molecule</i>	$\omega_e(\text{cm}^{-1})$	$\omega_e x_e(\text{cm}^{-1})$	<i>Reference</i>
$^7\text{LiF}$	910.16 $\pm$ 0.42	8.09 $\pm$ 0.15	22
$\text{NaF}$	536.10 $\pm$ 0.35	3.83 $\pm$ 0.14	18
$\text{KF}$	426.04 $\pm$ 0.24	2.43 $\pm$ 0.09	18
$^{85}\text{RbF}$	373.27 $\pm$ 0.08	1.80 $\pm$ 0.03	18
$^{87}\text{RbF}$	373.74 $\pm$ 0.14	2.18 $\pm$ 0.03	18
$\text{CsF}$	352.56 $\pm$ 0.04	1.62 $\pm$ 0.01	18
$^7\text{Li}^{35}\text{Cl}$	643.19 $\pm$ 0.28	4.51 $\pm$ 0.05	22
$\text{Na}^{35}\text{Cl}$	364.60 $\pm$ 0.10	1.755 $\pm$ 0.030	19
$\text{Na}^{37}\text{Cl}$	360.60 $\pm$ 0.10	1.740 $\pm$ 0.030	19
$\text{K}^{35}\text{Cl}$	279.80 $\pm$ 0.10	1.167 $\pm$ 0.005	19
$\text{K}^{37}\text{Cl}$	275.80 $\pm$ 0.20	1.113 $\pm$ 0.005	19
$^{85}\text{Rb}^{35}\text{Cl}$	233.34 $\pm$ 0.08	0.856 $\pm$ 0.008	19
$^{87}\text{Rb}^{35}\text{Cl}$	232.67 $\pm$ 0.08	0.870 $\pm$ 0.020	19
$^{85}\text{Rb}^{37}\text{Cl}$	228.88 $\pm$ 0.08	0.810 $\pm$ 0.040	19
$\text{Cs}^{35}\text{Cl}$	214.22 $\pm$ 0.05	0.740 $\pm$ 0.004	19
$\text{Cs}^{37}\text{Cl}$	209.55 $\pm$ 0.06	0.710 $\pm$ 0.020	19
$\text{Li}^{79}\text{Br}$	563.5 $\pm$ 2.2	3.88 $\pm$ 0.02	50
$\text{Li}^{81}\text{Br}$	561 $\pm$ 15	3.86 $\pm$ 0.1	50
$\text{Na}^{79}\text{Br}$	298.49 $\pm$ 0.17	1.16 $\pm$ 0.03	50
$\text{Na}^{81}\text{Br}$	298.00 $\pm$ 0.22	1.20 $\pm$ 0.05	50
$\text{K}^{79}\text{Br}$	219.170 $\pm$ 0.029	0.758 $\pm$ 0.005	50
$\text{K}^{81}\text{Br}$	218.271 $\pm$ 0.010	0.752 $\pm$ 0.005	50
$^{85}\text{Rb}^{79}\text{Br}$	169.46 $\pm$ 0.03	0.463 $\pm$ 0.007	50
$^{87}\text{Rb}^{79}\text{Br}$	168.46 $\pm$ 0.07	0.448 $\pm$ 0.007	50
$^{85}\text{Rb}^{81}\text{Br}$	168.32 $\pm$ 0.06	0.459 $\pm$ 0.006	50
$\text{Cs}^{79}\text{Br}$	149.503 $\pm$ 0.007	0.3602 $\pm$ 0.0008	50
$\text{Cs}^{81}\text{Br}$	148.301 $\pm$ 0.023	0.363 $\pm$ 0.035	50
$\text{LiI}$	490 $\pm$ 14	3.1 $\pm$ 0.1	50
$\text{NaI}$	259.20 $\pm$ 0.16	0.964 $\pm$ 0.024	50
$\text{KI}$	186.53 $\pm$ 0.04	0.574 $\pm$ 0.006	50
$^{85}\text{RbI}$	138.511 $\pm$ 0.035	0.335 $\pm$ 0.006	50
$^{87}\text{RbI}$	137.56 $\pm$ 0.05	0.330 $\pm$ 0.006	50
$\text{CsI}$	119.195 $\pm$ 0.013	0.2542 $\pm$ 0.0021	50

Our laboratory has now completed millimetre wave measurements on all the alkali halides. The results are reported in detail in a series of articles in the Physical Review, the latest of which gives results on the alkali fluorides. In *Tables 6, 7, and 8* some of the results are summarized. For most of the various isotopic species, many more transitions were measured than were required to yield the various constants, so that a self-consistent check on the measurements would be possible. An illustration of the consistency between the frequency measurements and the frequencies calculated with Dunham's theory<sup>51</sup> is given in *Table 6*. Only six terms in Dunham's expansions were found necessary to fit these data to the observed accuracy. The theory and calculations are described in the original papers cited.

It is of interest that the vibrational constants  $\omega_e$  and the anharmonicity constants  $\omega_e x_e$  are obtained much more precisely from these measurements than they could be obtained from direct infrared measurements of vibrational transitions. These vibrational constants are summarized in *Table 8*.

An important factor which makes it possible to observe sharp, strong lines of the alkali halides in the shorter millimetre region is the rapid decrease of nuclear quadrupole splitting of rotational lines with increasing

*J.* For most of the alkali halides, the nuclear quadrupole coupling produces only a slight broadening, usually less than 100 kc/s in the 1–2 mm region. For example, the KCl line shown in *Figure 14* for  $J = 12 \rightarrow 13$  is broadened less than 60 kc/s. Although the avoidance of nuclear quadrupole effects at high  $J$  is a great simplifying factor and one which makes possible very accurate evaluation of rotational and vibrational constants, it has a disadvantage in that nuclear coupling constants cannot be obtained from the measurements. Fortunately, the nuclear coupling constants of most of the alkali halides are known from measurements of molecular beam resonance in the radiofrequency region. It is obvious that the molecular beam measurements in the millimetre and the radio regions are more complementary than competitive.

Before our work on the alkali halides was done, Honig *et al.*<sup>52</sup> observed centimetre wave transitions for most of the alkali halides with an absorption cell heated to the vaporization temperature of the halides. Because of the large Doppler broadening and pressure broadening at these temperatures, their measurements were one or two orders of magnitude less accurate than those we obtained with the molecular beam spectrometer. Also they were unable to obtain reliable values for centrifugal stretching constants from centimetre wave measurements only. More recently, high-temperature absorption cells have been made to operate in the lower frequency millimetre wave region, 10–8 mm, by Lide *et al.*<sup>53</sup> and by Topping<sup>54</sup>, and in the centimetre range by Hoefl<sup>55</sup>.

The future projects which we shall attempt with the molecular beam spectrometer involve measurement of rotational transitions of some of the alkali hydrides and certain other metallic hydrides and halides. To measure the hydrides we must produce a system which has lower loss than the present one at the shorter submillimetre wavelengths. We also must overcome certain chemical and physical problems to obtain adequate molecular beams.

## SYMMETRIC AND ASYMMETRIC ROTORS

Even though all except the lighter symmetric and asymmetric top rotors have rotational transitions which occur in the centimetre or upper millimetre wave region, measurements in the shorter millimetre or submillimetre wave region are necessary for an accurate evaluation of the rather large effects of centrifugal distortion on the molecular constants of these molecules. Furthermore, measurements over a wide frequency range are usually necessary before correct assignment of the transitions of an asymmetric rotor can be made. For these and other reasons, it has been—or should have been—apparent to most spectroscopists since the first centimetre wave measurements after World War II that extension of the coverage of microwave spectroscopy throughout the millimetre and into the submillimetre region was imperative to realization of full spectral status for this new branch of spectroscopy. The opening of the 4–0.4 mm region together with the development and increasing availability of accurate, high-speed computers has now made the spectroscopy of asymmetric rotors a practical reality.

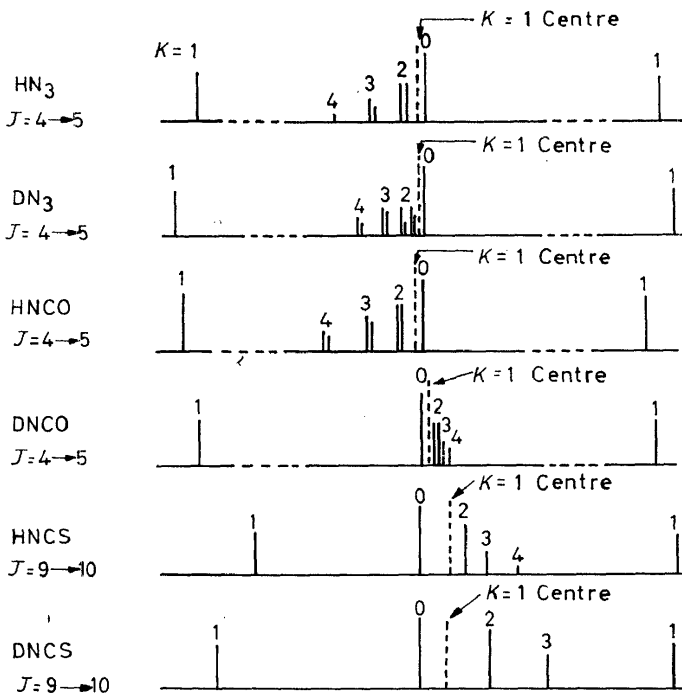

Figure 15. Illustration of the anomalous centrifugal distortion effects observed in the 3-1 mm wave region for some slightly asymmetric molecules. (After Kewley, Sastry and Winniewisser<sup>60,61</sup>)

# MICROWAVE SPECTROSCOPY

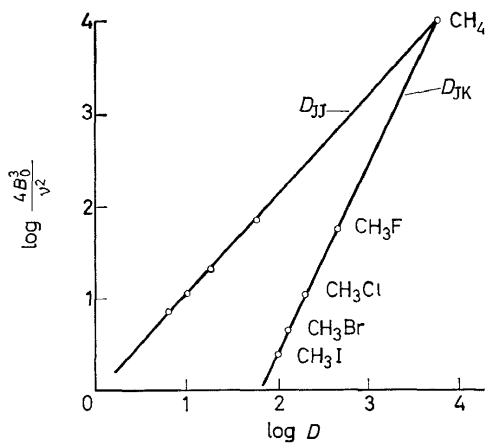

Figure 16. Relationship of the centrifugal distortion constants  $D_J$  and  $D_{JK}$  of the alkali halides as obtained from 4-1 mm wave spectroscopy. (After Orville Thomas, Cox and Gordy<sup>65</sup>)

A number of visiting scientists working in our laboratory have effectively employed 4–1 mm wave spectroscopy for the study of asymmetric rotors. Examples of the work are that of Trambarulo *et al.* on ozone<sup>56</sup>, that of Jache, Moser and Gordy on H<sub>2</sub>Se<sup>57</sup>, that of Erlandsson on formic acid<sup>58</sup>, that of Favero, Mirri, and Baker on formyl fluoride<sup>59</sup>, and that of Kewley, Sastry and Winnewisser on HNCS and HNCO<sup>60</sup>, and on HN<sub>3</sub><sup>61</sup> and their deuterated counterparts. The anomalous relationship of the distortion constants found for these molecules is illustrated by *Figure 15*. Erlandsson was one of the first to combine 4–1 mm wave spectroscopy with high-speed computer techniques<sup>62</sup> for the effective study of centrifugal distortion in asymmetric rotors. Examples of recent work in this field are the researches of Winnewisser and Cook on centrifugal distortion in HN<sub>3</sub> and all its isotopic species<sup>63</sup>, also that of Cook on nitrosyl fluoride<sup>64</sup>.

Analysis of effects of centrifugal stretching on symmetric rotors is simpler than that of asymmetric rotors, but it also requires measurements at higher millimetre or submillimetre wave frequencies. The work by Thomas, Cox and Gordy on the methyl halides<sup>65</sup> is an illustration of this type of study. *Figure 16* shows graphically the relationship of the distortion constants found for these molecules.

The increase of strength of molecular absorption with increase of frequency makes the study of rotational spectra of molecules in excited vibrational states more practical in the 4–0.4 mm range than in the lower frequency microwave region. Like the study of the effects of centrifugal distortion, this work is mostly in the future, but examples of what can be done are provided in the study of interaction between the vibrational and rotational motions which give rise to the *l*-type doublets of methyl cyanide by Venkateswarlu, Baker and Gordy<sup>66</sup>.

Some symmetric top molecules, like many diatomic molecules, have such small moments of inertia that they have observable rotational lines only in the wavelength region below 4 mm. Illustrative results obtained for some of these molecules are given in *Table 9*.

*Table 9.* Molecular constants of some symmetric top molecules obtained from measurements in the 4–1 mm wave region

<i>Molecule</i>	$B_0$ (Mc/s)	$eQq$ coupling for N, As, or Sb	<i>Bond angle</i>	<i>Bond length</i> (Å)	<i>Reference</i>
<sup>14</sup> ND <sub>3</sub>	154,162.7	–4.10	107°	1.0144	67
PH <sub>3</sub>	133,478.3	—	93° 27'	1.4206	68
PD <sub>3</sub>	69,470.41	—	93° 10'	1.4166	68
<sup>75</sup> AsH <sub>3</sub>	112,468.46	–160.1	91° 50'	1.5192	69
<sup>75</sup> AsD <sub>3</sub>	57,477.15	–165.9	91° 30'	1.5145	69
<sup>121</sup> SbH <sub>3</sub>	88,031.92	458.7	91° 18'	1.7073	70
<sup>121</sup> SbD <sub>3</sub>	44,693.29	465.4	90° 56'	1.7021	70
<sup>123</sup> SbH <sub>3</sub>	88,015.54	586.0	91° 18'	1.7073	70
<sup>123</sup> SbD <sub>3</sub>	44,677.13	592.8	90° 56'	1.7021	70

## SOLIDS, LIQUIDS AND FLAMES

Smyth's group<sup>71</sup> at Princeton and Schneider<sup>72</sup> at Duke have used our harmonic generator for study of dielectric absorption of liquids in the 3 mm

region. In the 4 mm region, van Roggen, van Roggen and Gordy<sup>73</sup> have used it for the measurement of paramagnetic resonance of free radicals in single crystals of DPPH and similar substances. The advantage of high frequencies in the resolution of small anisotropies in the spectroscopic splitting factor  $g$  in paramagnetic resonance is demonstrated.

At Duke, Schneider and Hofmann<sup>74</sup>, also Bulewicz and Padley<sup>75</sup>, developed a highly effective method for the study of combustion processes through millimetre-wave cyclotron resonances in gaseous flames. The experiments they performed in the 8–6 mm region would have been more effective if done in the 4–1 mm region, but, unfortunately, they did not have available a suitable, high-field magnet for detection of resonances in that region. Because the observation frequency must be large as compared with the collision frequency which determines the line breadth, the flames must be burned at sub-atmospheric pressures when the resonances are observed in the 8–6 mm region. With magnets now commercially available, one can apply this method in the one millimetre region where it should be possible to study combustion processes at pressures of the order of an atmosphere.

Many resonances of solids—antiferromagnetic resonance, cyclotron resonance, transitions from superconducting to normal states, lattice and molecular vibrational transitions—occur within the submillimetre wave region which is now accessible to microwave measurements. However, it seems inefficient, if not downright wasteful, to use a high-resolution source for study of very broad resonances. As is apparent from the illustrations, we have concentrated our principal efforts on sharp-line spectra. With use of single crystals, highly purified materials, and low-temperature techniques, however, one should be able to sharpen many submillimetre wave resonances of solids to the degree that a high-resolution sweep spectrometer becomes of advantage for observation of them. Study of sharp-line spectra of solids is among the future applications of submillimetre wave spectroscopy.

## References

- <sup>1a</sup> W. C. King and W. Gordy. *Phys. Rev.* **90**, 319 (1953).
- <sup>1b</sup> C. A. Burrus and W. Gordy. *Phys. Rev.* **92**, 274, 1437 (1953).
- <sup>2</sup> C. A. Burrus and W. Gordy. *Phys. Rev.* **93**, 897 (1954).
- <sup>3</sup> L. Genzel and W. Eckhardt. *Z. Physik* **139**, 592 (1954).
- <sup>4</sup> M. Cowan and W. Gordy. *Phys. Rev.* **104**, 551 (1956).
- <sup>5</sup> G. Jones and W. Gordy. *Phys. Rev.* **135**, A295 (1964).
- <sup>6</sup> E. F. Nichols and J. D. Tear. *Phys. Rev.* **21**, 587 (1923); *Proc. Natl. Acad. Sci. U.S.A.* **9**, 211 (1923).
- <sup>7a</sup> J. H. N. Loubser and C. H. Townes. *Phys. Rev.* **76**, 178 (1949).
- <sup>7b</sup> J. H. N. Loubser and J. A. Klein. *Phys. Rev.* **78**, 348 (1950).
- <sup>8</sup> K. D. Froome. *Nature* **186**, 959 (1960); **188**, 43 (1960).
- <sup>9</sup> P. H. Knapp and D. H. Martin. Abstract 221. *8th European Congress on Molecular Spectroscopy* (1965).
- <sup>10</sup> R. Beringer. *Phys. Rev.* **70**, 53 (1946).
- <sup>11a</sup> H. A. Gebbie, N. W. B. Stone, and F. D. Findlay. *Nature* **202**, 685 (1964).
- <sup>11b</sup> G. W. Chantry, H. A. Gebbie, and J. E. Chamberlain. *Nature* **205**, 377 (1965).
- <sup>12</sup> W. Gordy. "Millimeter and Submillimeter Waves in Physics." In *Proceedings of the Symposium on Millimeter Waves*, Polytechnic Press of the Polytechnic Institute of Brooklyn, New York (1960).
- <sup>13</sup> W. Gordy. *Ann. N.Y. Acad. Sci.* **55**, 774 (1952).

W. GORDY

- <sup>11</sup> W. Gordy. *J. Phys. Radium* **15**, 521 (1954).
- <sup>15</sup> W. Gordy. *Sci. Am.* **196**, 46 (1957).
- <sup>16</sup> W. Gordy, W. V. Smith, and R. F. Trambarulo. *Microwave Spectroscopy*, Chap. 1. John Wiley, New York (1957).
- <sup>17</sup> C. A. Burrus and W. Gordy. *Phys. Rev.* **101**, 599 (1956).
- <sup>18</sup> S. E. Veazey and W. Gordy. *Phys. Rev.* **138**, A1303 (1965).
- <sup>19</sup> P. L. Clouser and W. Gordy. *Phys. Rev.* **134**, A863 (1964).
- <sup>20</sup> G. Erlandsson and W. Gordy. *Phys. Rev.* **106**, 513 (1957).
- <sup>21</sup> O. R. Gilliam, C. M. Johnson, and W. Gordy. *Phys. Rev.* **78**, 140 (1950).
- <sup>22</sup> E. F. Pearson and W. Gordy. To be published.
- <sup>23</sup> M. Cowan and W. Gordy. *Bull. Am. Phys. Soc.* **2**, 212 (1957).
- <sup>24</sup> M. Cowan and W. Gordy. *Bull. Am. Phys. Soc.* **5**, 241 (1960).
- <sup>25</sup> A. G. Smith, W. Gordy, J. W. Simmons, and W. V. Smith. *Phys. Rev.* **75**, 260 (1949).
- <sup>26</sup> W. Gordy. *Rev. Mod. Phys.* **20**, 668 (1948).
- <sup>27</sup> W. C. King and W. Gordy. *Phys. Rev.* **93**, 407 (1954).
- <sup>28</sup> R. S. Ohl, P. P. Budenstein, and C. A. Burrus. *Rev. Sci. Instr.* **30**, 765 (1959).
- <sup>29</sup> M. Cowan. *Ph.D. Thesis, Duke University* (1959).
- <sup>30</sup> G. Jones. *Ph.D. Thesis, Duke University* (1964).
- <sup>31</sup> G. Jones and W. Gordy. *Phys. Rev.* **136**, A1229 (1964).
- <sup>32</sup> M. Cowan and W. Gordy. *Phys. Rev.* **111**, 209 (1958).
- <sup>33</sup> C. A. Burrus, W. Gordy, B. Benjamin, and R. Livingston. *Phys. Rev.* **97**, 1661 (1955).
- <sup>34</sup> D. H. Rank, D. P. Eastman, B. S. Rao, and T. A. Wiggins. *J. Opt. Soc. Am.* **52**, 1 (1962).
- <sup>35</sup> K. D. Froome. *Proc. Roy. Soc. (London)* **A247**, 109 (1958).
- <sup>36</sup> E. Bergstrand. *Nuovo Cimento, Suppl.* **6**, 224 (1957).
- <sup>37</sup> J. W. M. Dumond and E. R. Cohn. In *Handbook of Physics* (Ed. E. U. Condon and H. Odishaw), part 7, chapter 10, p. 143. McGraw-Hill, New York (1958).
- <sup>38</sup> O. Fujii. "A Stark Effect Microwave Spectrometer for the Shorter Millimeter Wave-Region." *M.A. Thesis, Duke University* (1954).
- <sup>39</sup> B. N. Bhattacharya and W. Gordy. *Phys. Rev.* **119**, 144 (1960).
- <sup>40</sup> B. N. Bhattacharya. "Stark and Zeeman Effect Studies of HCN." *Ph.D. Thesis, Duke University* (1958).
- <sup>41</sup> R. H. Hughes and E. B. Wilson, Jr. *Phys. Rev.* **71**, 562 (1947).
- <sup>42</sup> K. White. "The Stark Effect for Slightly Asymmetric Reactors." *Ph.D. Thesis, Duke University* (1965).
- <sup>43</sup> D. M. Larkin and W. Gordy. *J. Chem. Phys.* **38**, 2329 (1963).
- <sup>44</sup> P. A. Steiner. "Stark Effect Studies of CH<sub>3</sub>F, CD<sub>3</sub>F, CH<sub>3</sub>CN, and CD<sub>3</sub>CN." *Ph.D. Thesis, Duke University* (1964).
- <sup>45</sup> R. Kewley, K. V. L. N. Sastry, M. Winnewisser, and W. Gordy. *J. Chem. Phys.* **39**, 2856 (1963).
- <sup>46</sup> M. Winnewisser, K. V. L. N. Sastry, R. L. Cook, and W. Gordy. *J. Chem. Phys.* **41**, 1687 (1964).
- <sup>47</sup> M. Winnewisser and G. Winnewisser. To be published.
- <sup>48</sup> M. Winnewisser, G. Winnewisser and W. Gordy. *Bull. Am. Phys. Soc.* **10**, 490 (1965). Most of the lines reported in this abstract as due to SH have been identified as arising from H<sub>2</sub>S<sub>2</sub>.
- <sup>49</sup> A. K. Garrison and W. Gordy. *Phys. Rev.* **108**, 899 (1957).
- <sup>50</sup> J. R. Rusk and W. Gordy. *Phys. Rev.* **127**, 817 (1962).
- <sup>51</sup> J. L. Dunham. *Phys. Rev.* **41**, 721 (1932).
- <sup>52</sup> A. Honig, M. Mandel, M. L. Stitch, and C. H. Townes. *Phys. Rev.* **96**, 629 (1954).
- <sup>53</sup> D. R. Lide, Jr., P. Cahil, and L. P. Gold. *J. Chem. Phys.* **40**, 156 (1964).
- <sup>54</sup> T. Torring. *Z. Naturforsch.* **19a**, 1426 (1964).
- <sup>55</sup> J. Hoefl. *Z. Naturforsch.* **19a**, 1134 (1964).
- <sup>56</sup> R. Trambarulo, S. N. Ghosh, C. A. Burrus, and W. Gordy. *J. Chem. Phys.* **21**, 851 (1953).
- <sup>57</sup> A. W. Jache, P. M. Moser and W. Gordy. *J. Chem. Phys.* **25**, 209 (1956).
- <sup>58</sup> G. Erlandsson. *J. Chem. Phys.* **28**, 71 (1958).
- <sup>59</sup> P. Favero, A. M. Mirri, and J. G. Baker. *J. Chem. Phys.* **31**, 566 (1959); *Nuovo Cimento* **17**, 740 (1960).
- <sup>60</sup> R. Kewley, K. V. L. N. Sastry, and M. Winnewisser. *J. Mol. Spectry* **10**, 418 (1963).
- <sup>61</sup> R. Kewley, K. V. L. N. Sastry and M. Winnewisser. *J. Mol. Spectry* **12**, 387 (1964).
- <sup>62</sup> G. Erlandsson. *Arkiv Fysik* **16**, 181 (1959).

## MICROWAVE SPECTROSCOPY

- <sup>63</sup> M. Winnewisser and R. L. Cook. *J. Chem. Phys.* **41**, 999 (1964).  
<sup>64</sup> R. L. Cook. *J. Chem. Phys.* **42**, 2927 (1965).  
<sup>65</sup> W. J. Orville Thomas, J. T. Cox, and W. Gordy. *J. Chem. Phys.* **22**, 1718 (1954).  
<sup>66</sup> P. Venkateswarlu, J. G. Baker, and W. Gordy. *J. Mol. Spectry* **6**, 215 (1961).  
<sup>67</sup> G. Erlandsson and W. Gordy. *Phys. Rev.* **106**, 513 (1957).  
<sup>68</sup> C. A. Burrus, A. W. Jache, and W. Gordy. *Phys. Rev.* **95**, 706 (1954).  
<sup>69</sup> G. S. Blevins, A. W. Jache, and W. Gordy. *Phys. Rev.* **97**, 684 (1955).  
<sup>70</sup> A. W. Jache, G. S. Blevins, and W. Gordy. *Phys. Rev.* **97**, 680 (1955).  
<sup>71</sup> R. W. Rampalla, R. C. Miller, and C. P. Smyth. *J. Chem. Phys.* **30**, 566 (1959).  
<sup>72</sup> J. Schneider. *J. Chem. Phys.* **32**, 665 (1960).  
<sup>73</sup> A. van Roggen, L. van Roggen, and W. Gordy. *Phys. Rev.* **105**, 50 (1957).  
<sup>74</sup> J. Schneider and F. W. Hoffman. *Phys. Rev.* **116**, 244 (1959).  
<sup>75</sup> E. M. Bulewicz and P. J. Padley. *J. Chem. Phys.* **35**, 1590 (1961); *J. Chem. Phys.* **36**, 2231 (1962).