

THE HIGHLY-OXYGENATED DITERPENOID ALKALOIDS

L. MARION

Division of Pure Chemistry, National Research Council, Ottawa, Canada

Just a few years ago the bases occurring in the *Aconitum* and *Delphinium* species of plants presented one of the major unsolved problems of natural products chemistry. As a result of the work done in the last 7 or 8 years it is now possible to classify these bases, which are diterpenoid in nature, according to their carbon-nitrogen skeletons into three groups. The alkaloids

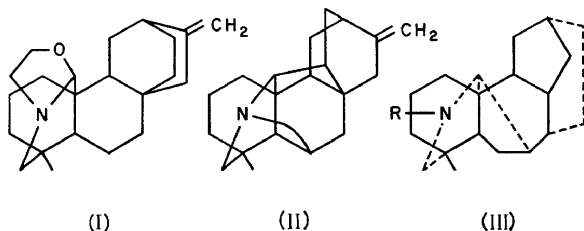

of groups (I) and (II) do not usually contain many oxygenated substituents whereas those belonging to group (III) are generally highly-oxygenated. It is this last group that I wish to discuss.

Both aconitine and delphinine, which have been isolated a long time ago, and are typical of the highly-oxygenated diterpenoid alkaloids, have been the subject of intense investigations over many years. It is only after the determination of the structure of lycoctonine that rapid progress was achieved in establishing the structures of these bases and of their congeners. The complete formula, and the chemistry of lycoctonine, proved to be the key to the structural problems presented by these complex substances.

Lycoctonine ($C_{25}H_{41}O_7N$) occurs in both *Aconitum* and *Delphinium* plants. It occurs in the form of a monoester amide or imide of anthranilic acid with either acetic acid (ajacine), succinic acid (lycaconitine) or methylsuccinic acid (methyllycaconitine)¹. Lycoctonine contains an imino-ethyl group, three hydroxyls and four methoxyls. One of the hydroxyls is primary and the other two are present in a tertiary α -glycol grouping. Various oxidative reactions made it possible to establish the nature of four of the six rings present in the base, and to locate six of the eight substituents². The complete structure (IV), however, was obtained by X-ray crystallography by Mrs Maria Przybylska³.

Lycoctonine undergoes quite a number of acid-catalysed and base-catalysed rearrangements⁴ and the nature of all but one of the products has

been determined^{5, 6}. Also, the absolute configuration of the molecule was determined by further refinement of the X-ray data⁷. Hence the structure of the alkaloid has been rigorously established both by physical and chemical means, and an understanding of its various transformations as will appear has proved useful in later correlations.

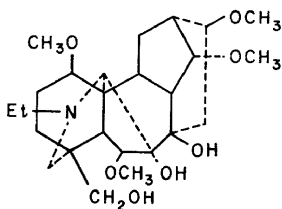

(IV)

The first to use this structure as a guide were Cookson and Trevett⁸ who assumed that the alkaloid delpheline ($C_{25}H_{39}O_6N$) (V) possessed the same carbon-nitrogen skeleton. They found that all the chemical reactions of

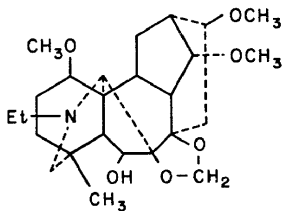

(V)

demethylene-delpheline could be reconciled with that structure and were comparable to those of lycoctonine.

Indeed, demethylene-delpheline has been converted by Carmack⁹ to deoxylycoctonine by methylation, and we also have correlated it by the conversion of lycoctonine into a diketone also obtainable from delpheline¹⁰. This conversion is based on the readiness with which oxo-lycoctonine undergoes a pinacolic rearrangement by treatment with acid. The resulting pinacone has lost the α -glycol system and possesses a carbonyl which is α to a methoxyl group. Such a methoxyl is smoothly removed by the action of sodium amalgam and the product (VI) is oxidizable with selenium dioxide to a diketone (VII). These correlations prove the correctness of the assignment of structure to demethylene-delpheline, but although Cookson favoured the view that delpheline itself had the same carbon-nitrogen skeleton, he did not completely discard the possibility that delpheline could undergo a rearrangement during demethylenation.

HIGHLY-OXYGENATED DITERPENOID ALKALOIDS

Carmack and his co-workers⁹ established that the alkaloid deltaline ($C_{27}H_{41}O_8N$) was a hydroxy-acetyldepheline from which the free hydroxyl could be removed by chlorination with thionyl chloride followed by refluxing in collidine. The dehydrodeoxydeltaline thus obtained gave rise, when catalytically hydrogenated, to a dihydro-derivative, identical with

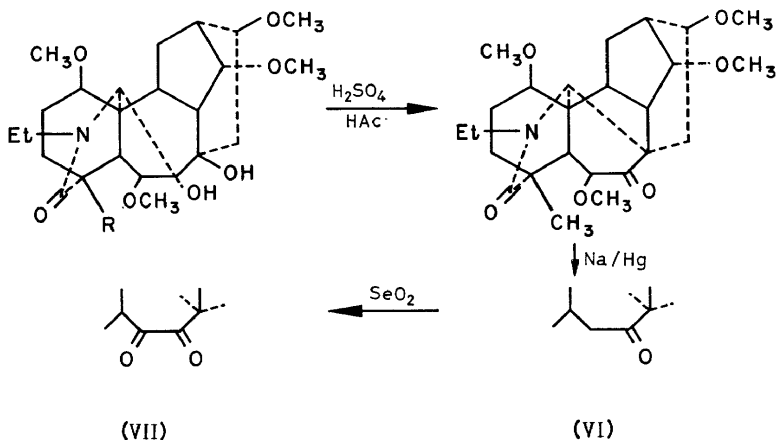

acetyldepheline. Saponification and demethylenation of this substance followed by methylation of the initially acetylated hydroxyl gave a product which was identical with deoxylycoctonine. They concluded that both delpheline and deltaline had the same carbon-nitrogen nucleus as lycoctonine.

In a further study, Carmack, Mayo and Ferris¹¹ found that demethylene-deltamine (demethylene-deacetyldeltaline) consumed two moles of periodic acid to give a diketo-acid which spontaneously formed a γ -lactone, thus locating the additional hydroxyl at R (VIII, R=OH).

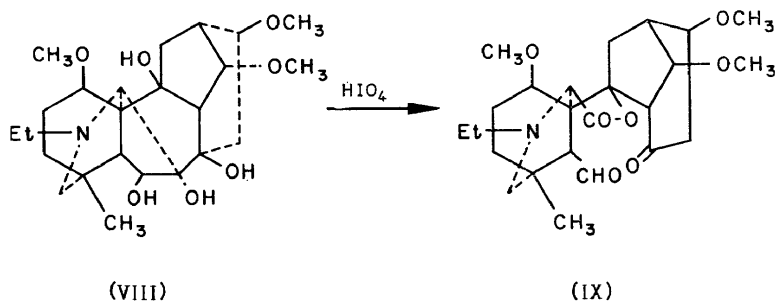

In deltaline itself this hydroxyl can be removed readily with the resulting formation of a double bond which they claim cannot be accommodated in the lycoctonine structure without an unacceptable violation of Bredt's rule.

They also state that the pattern of reactivity of this hydroxyl is quite different from that of the hydroxyl in β -caryophyllene alcohol which contains a bicyclo[4,3,1]decane system similar to that present in the lycoctonine skeleton. Their conclusion is that both delpheline and deltaline must have a ring structure different from that of lycoctonine and they propose to represent

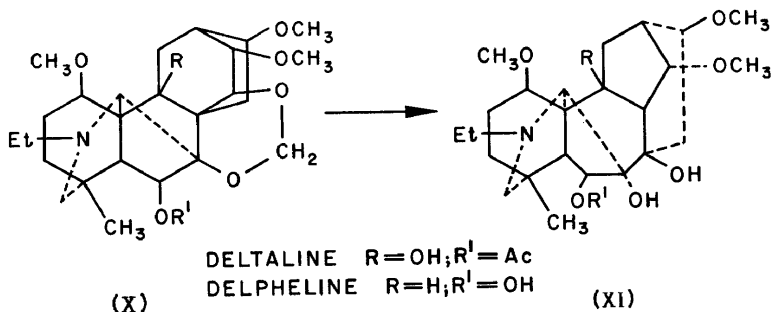

these two alkaloids by formula (X) which can be conceived as that of a possible biogenetic precursor of the lycoctonine skeleton.

Although this possibility, which is a most interesting one, cannot at the present time be discarded definitely, the arguments used by Carmack in favour of it are misleading. The lycoctonine skeleton cannot be considered

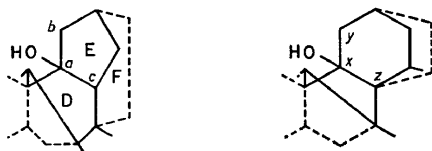

E + F - BICYCLO [3,2,1] OCTANE

D + E BICYCLO [4,3,0] NONANE

to contain a bicyclo[4,3,1]decane system unless one includes three rings in it (rings D, E, and F). It does, however, contain a bicyclo[3,2,1]octane and a bicyclo[4,3,0]nonane. If on the one hand we consider the hydroxyl in question to belong to the bicyclo-octane system, a double bond could not form between *a* and *c* without violating Bredt's rule, but it could form between *a* and *b*. On the other hand, if we consider the hydroxyl as belonging to the bicyclo[4,3,0]nonane system, Bredt's rule does not apply and elimination could take place between *a* and *b*.

In the new structure proposed by Carmack a similar bicyclo[4,3,0]nonane system exists and the only way in which elimination could occur is between *x* and *y*. Consequently, the point around which the argument evolves is whether the formation of a double bond exocyclic to a cyclohexane ring—when it cannot possibly be endocyclic under the circumstances—is so

HIGHLY-OXYGENATED DITERPENOID ALKALOIDS

impossible as to prevent the elimination. The existence in the steroid series, which contain the [4,3,0] system, of four different β - or Δ^{14} -stenols¹² should be sufficient evidence that this is not *a priori* so. Consequently, the necessity of a rearrangement of the skeleton in going from deltaline to the demethylenated alkaloid has not been demonstrated. The fact that has been firmly established, however, is that both delpheline and deltaline after demethylenation do possess the lycoctonine skeleton.

The methylenedioxy group has also been found in the alkaloid elatine ($C_{38}H_{50}O_{10}N_2$). Elatine has been shown by Kusowkow¹³ to yield, on hydrolysis, anthranilic acid, methylsuccinic acid, and the base elatidine ($C_{26}H_{41}O_7N$) which is the methylenedioxy derivative of lycoctonine.

The even more complex bases aconitine and delphinine fall into this group, although they both undergo a reaction on pyrolysis which does not occur with lycoctonine. Delphinine ($C_{33}H_{45}O_9N$) can be saponified to acetic acid, benzoic acid and delphonine ($C_{24}H_{39}O_7N$). It has been investigated by many, but particularly by W. A. Jacobs and his collaborators¹⁴ who established much of the chemistry of the base and clarified the nature of its substituents. It was, however, Wiesner and his students^{15, 16} who assigned to it the lycoctonine skeleton, located its substituents, and showed that the evidence accumulated by Jacobs could be reconciled with the assigned structure (XII).

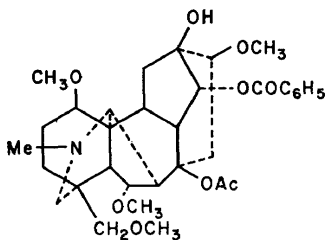

(XII)

Aconitine differs from delphinine in that it contains an imino-ethyl instead of an imino-methyl group, and also two additional hydroxyls. By assuming that aconitine possessed the same carbon-nitrogen skeleton as lycoctonine, as Schneider¹⁷ was the first to do, and by taking into account the reactions of pyraconitine it was possible to determine that one of the additional hydroxyls was secondary and to locate it tentatively in ring F between the acetoxy and methoxy groups¹⁸.

Aconitine is oxidized by chromic acid to a weak keto-base which very readily loses a methoxyl group and gives rise to an $\alpha\beta$ -unsaturated ketone, aconitoline. Because of the dramatic effect of this oxidation on the basicity, the β -hydroxy-methoxy system involved was assumed to be present in ring A¹⁹. The hydrobromide of the saponification product of aconitoline, *i.e.* aconinone hydrobromide, was subjected to an X-ray crystallographic study²⁰, and found to possess, as assumed, the lycoctonine skeleton (XIII).

L. MARION

The location of the keto group in ring A establishes the positions of both the secondary hydroxyl and the methoxyl groups present in this ring, but does not give their stereochemistry although that of the remaining substituents is given. The absolute configuration of the molecule was obtained by a refinement of the X-ray data⁷. It is noteworthy that of all those substituents which

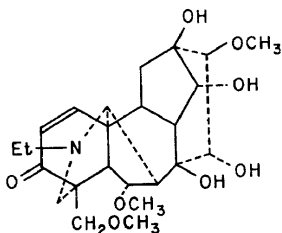

(XIII)

aconitine has in common with lycotoxine, the only one having a different configuration is the methoxyl at C-6.

Simultaneously and independently, Wiesner and Büchi with their respective collaborators²¹ arrived both by chemical means and by analogy to the identical structure and also located the benzoyl group. The stereochemistry

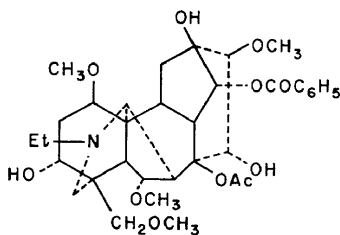

(XIV)

of the two substituents in ring A was determined by Büchi²². Wiesner, who applied these findings to delphinine¹⁶ succeeded in correlating the two bases by conversion to a common intermediate¹⁸.

There are a number of alkaloids that appear to be closely related to delphinine and aconitine and the structures of several of these have been solved. Pelletier²⁴ and also Turner²⁵ succeeded in showing that oxonitine, the permanganate oxidation product of aconitine, was *N*-formyl(desethyl)aconitine and that it is also obtainable from mesaconitine by oxidation. Since reduction of oxonitine with LiAlH₄ produces mesaconine, it follows that mesaconitine is *N*-methyl(desethyl)aconitine.

Two other alkaloids which have been isolated a very long time ago are indaconitine (C₃₄H₄₇O₁₀N) and pseudaconitine (C₃₆H₅₁O₁₂N). While on

HIGHLY-OXYGENATED DITERPENOID ALKALOIDS

hydrolysis the first gives acetic acid, benzoic acid and pseudoaconine ($C_{25}H_{41}O_8N$), the second gives acetic acid, veratric acid and pseudoaconine. Both contain an ethylimino group, and both on heating form pyro-derivatives. The pyro-derivatives obtainable from aconitine and delphinine are illustrated by the following partial formulae:

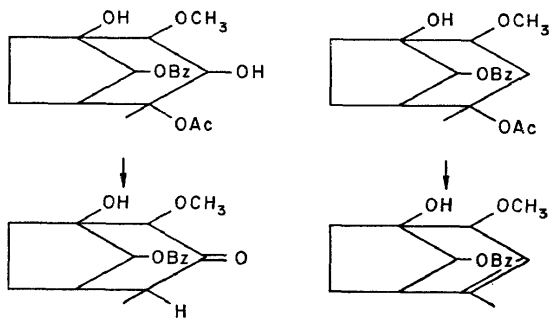

In aconitine elimination of the acetoxy group in the pyrolysis gives rise to a keto-derivative while in delphinine the formation of a carbonyl is impossible and an olefinic bond is introduced.

Pyropseudoaconine according to its infra-red spectrum does not contain a carbonyl and, consequently, if we assume indaconitine and pseudoaconitine to have the same carbon-nitrogen skeleton as lycotoxine, both probably have a ring F which is substituted as in delphinine except that pseudoaconitine contains a veratroly instead of a benzoyl group.

On the other hand pseudoaconitine is oxidized by chromic acid to a weak keto base which loses the elements of methanol readily²⁶. This is reminiscent of the formation of aconitoline by the chromic acid oxidation of aconitine. It is probable then that indaconitine and pseudoaconitine both contain a secondary hydroxyl in ring A in a position *meta* to the methoxyl. It appears likely, therefore, that indaconitine should have structure (XV) (R = benzoyl). This is sufficiently close to the structure of delphinine that it was thought best as proof of structure to attempt the conversion of one alkaloid into the other.

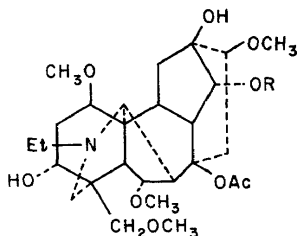

(XV)

L. MARION

Treatment of indaconitine with thionyl chloride removed the secondary hydroxyl of ring A and produced anhydro-indaconitine which on catalytic hydrogenation gave deoxyindaconitine. When this was oxidized with mercuric acetate it lost the imino-ethyl group and was converted to a secondary base. This base can be methylated with methyl iodide and the

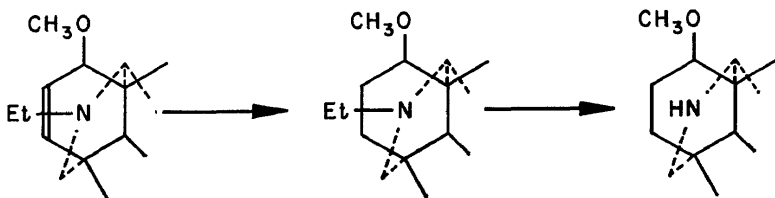

product, *N*-methyl-desethyl-deoxyindaconitine is identical in every respect with an authentic sample of delphinine. They were compared by their melting points and that of the mixture, their infra-red spectra and X-ray diffraction patterns, which were all identical²⁷.

Consequently, indaconitine has structure (XV) (R = benzoyl) while pseudoaconitine possesses the same structure with the exception that the benzoyl group is replaced by a veratroyl group²⁷ (XV, R = veratroyl).

Still another alkaloid of the ester group is jesaconitine (C₃₅H₄₉O₁₂N). On saponification it yields acetic acid, *p*-anisic acid and aconine. Furthermore, on heating it loses the elements of acetic acid and forms pyrojesaconitine which is hydrolyzable to pyraconine²⁸. It is highly probable, therefore, that jesaconitine has the same structure as aconitine with the exception that the benzoyl group of aconitine is replaced by a *p*-anisoyl group.

Neoline (C₂₄H₃₅O₆N) is one of the minor bases occurring with aconitine. It has been investigated by Wiesner²⁹ who proposes for its structure (XVI).

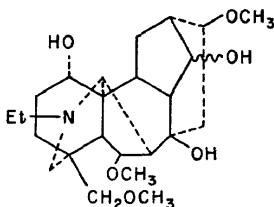

(XVI)

It seems to be more closely related to delcosine than to aconine. It could conceivably be an artefact and be a product of hydrolysis during the process of isolation.

Finally, I want to discuss two alkaloids, delcosine (C₂₄H₃₉O₇N) and delso-line (C₂₅H₄₁O₇N) which occur together in *Delphinium consolida*. Both contain

HIGHLY-OXYGENATED DITERPENOID ALKALOIDS

an ethylimino group and whereas delcosine contains four hydroxyls and three methoxyls, delsoline contains three hydroxyls and four methoxyls.

Delcosine is oxidized by chromic acid to a diketo-lactam in which one of the keto groups is in a five-membered ring and the other in a six-membered or larger ring³⁰. On the other hand, delsoline is oxidized by chromic acid to a keto-lactam in which the keto group is in a six-membered or larger ring³¹, so that delcosine contains two secondary hydroxyls while delsoline contains only one. Further, the Oppenauer oxidation of delcosine gives rise to a mono-ketone, dehydrodelcosine, in which the carbonyl is in a five-membered ring³². Consequently, the secondary hydroxyl in the five-membered ring is more readily amenable to reaction than the other. This is also true of acetylation. Although delcosine forms a diacetyl derivative, acetylation under controlled conditions affects the hydroxyl in the five-membered ring only.

Because of the remarkable parallelism between the reactions of delcosine and delsoline it was suspected that one might be the methyl ether of the other. And indeed treatment of delcosine with sodium hydride and methyl iodide methylated the secondary hydroxyl in the five-membered ring and gave rise to delsoline³³.

Delcosine is widely distributed and it has been found to be identical with "alkaloid C" of Goodson, with the delphamine of Kuzowkow and with the Takaobase I of Ochiai. It is also very probably identical with the lucaconine of Suginome. Derivatives of delcosine in which the secondary hydroxyl in the five-membered ring is blocked or oxidized, also occur in nature. Delsoline is the methyl derivative, and monoacetyl delcosine has been shown to be identical with Goodson's "alkaloid B" while the oxidation product dehydrodelcosine is identical with Ochiai's Shimoburobase II.

The reactions of delcosine already mentioned as well as all the others that have been studied, are all reconcilable with the assignment to delcosine of the lycotonine skeleton. Tentatively, therefore, delcosine has been represented by structure (XVII).

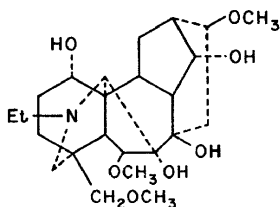

(XVII)

The presence of a tertiary α -glycol is demonstrated by the oxidation of oxodelcosine with periodic acid to a diketone in which one of the carbonyls is present in a five-membered ring and the other in a six-membered ring^{30, 34}. Treatment of this diketone with acid removes the elements of methanol and gives rise to an $\alpha\beta$ -unsaturated ketone³⁴ thus locating the methoxyl at C-16. The formation of a pinacone³⁵, to which I shall refer later, also militates in

favour of this structure. The alkyl group on the nitrogen can be removed with mercuric acetate, and the resulting dealkyldelcosine converted back to delcosine by the action of ethyl iodide³⁰, thus proving the nature of the substituent.

In the periodic acid oxidation, however, in order to isolate the diketone as such it is necessary first to block the hydroxyl in ring A. In the presence of the free hydroxyl the carbonyl in the six-membered ring of the oxidation product forms a hemi-ketal.

The orientation of the secondary hydroxyl in ring A is noteworthy. It is different from that of the methoxyl that occupies that position in lycotoxine. One of the products of the oxidation of delcosine is a substance ($C_{24}H_{37}O_7N$) which contains two hydrogens less and is a very much weaker base. Its infra-red spectrum shows no carbonyl absorption but contains two sharp bands at 1000 and 900 cm^{-1} which are absent in the spectrum of delcosine and are indicative of a cyclic ether. Whereas delcosine contained four active hydrogens, only three were present in the oxidation product and the latter combined with mineral acids to form anhydronium salts. Hence, one of the positions next to the nitrogen must be involved. The most satisfactory explanation is that a carbinolamine is first formed and that there is elimination of water between the new hydroxyl and the original secondary hydroxyl in ring A with the formation of a cyclic ether³². Thus it follows that the ring A hydroxyl must be directed towards the same side of ring A as the nitrogen group. Therefore any attempt to prove the assigned structure of delcosine by

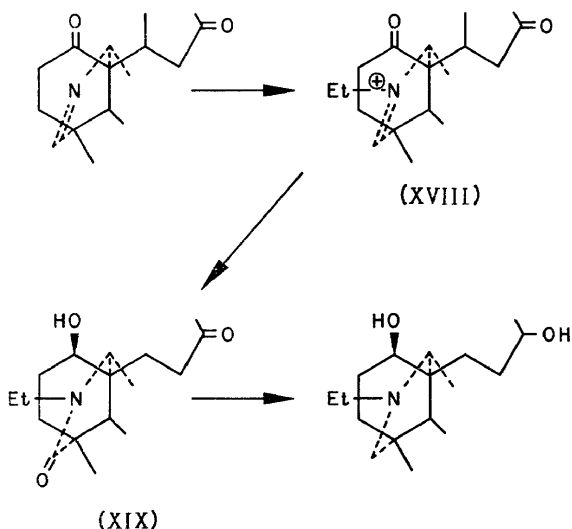

correlation with lycotoxine, must involve first the epimerization of the ring A hydroxyl. This has been accomplished from *N*-desethyldehydrodelcosine, obtained by oxidation of delcosine with mercuric acetate. The starting material was oxidized with Sarett's reagent to *N*-desethyldehydrodelcosine-azomethine (XVIII). The ethiodide of the azomethine when

HIGHLY-OXYGENATED DITERPENOID ALKALOIDS

refluxed with 10 per cent methanolic potassium hydroxide yielded dehydro-oxo-epidelcosine (XIX). This when reduced first with sodium borohydride and then with LiAlH_4 gave epidelcosine³⁶.

One way to correlate delcosine with lycoctonine would be to compare epidelcosine, in which the two secondary hydroxyls had been methylated, with lycoctonine in which the primary hydroxyl was methylated. The methylation of lycoctonine, however, could not be accomplished in good yields, and it proved necessary to use a dodge³⁶.

It had been found that oxolycoctonine under the influence of acid underwent a pinacolic transformation as a result of which the α -glycol system was eliminated giving rise to anhydro-oxolycoctonine (XX) ($\text{R} = \text{H}$). Methylation of the pinacone gave the desired product (XX, $\text{R} = \text{CH}_3$).

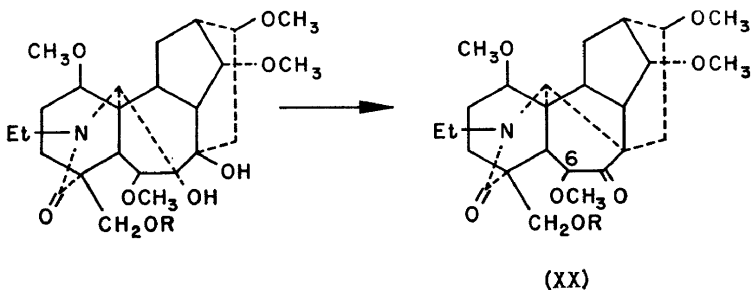

The lactam of epidelcosine also underwent the pinacolic transformation and the product was converted, by methylation of its two secondary hydroxyls, into *O,O*-dimethyl-anhydro-oxo-epidelcosine. This compound should have been identical with anhydro-oxolycoctonine. It had, however, a different melting point and a very different optical rotation than the substance derived from lycoctonine. The infra-red spectra of the two showed differences in the finger-print region. Since the methoxyl at C-6 in lycoctonine is stereochemically different from the same group in aconitine, it was possible that this feature might also exist in delcosine. Removal of the methoxyl in the 6-position (XX) from both compounds with sodium amalgam gave a pair of substances that still had different melting points and optical rotations. The infra-red spectra of the two products still showed slight but significant differences. Furthermore, according to the optical rotatory dispersion of the two pinacones containing the C-6 methoxyl, this group should have the same orientation in delcosine as in lycoctonine.

The smooth removal of the C-6 methoxyl with sodium amalgam, however, unambiguously locates that substituent next to the α -glycol. In view of the fact that the assignment of the lycoctonine skeleton to delcosine accommodates all the chemical reactions of the alkaloid so well, and permits a rational location of its substituents, it is very unlikely that the failure of the attempted correlation could indicate that the assignment was in error. It is more probably attributable either to a stereochemical difference of other substituents besides the C-1 hydroxyl, or to a different conformation of one or more of the rings in the skeleton.

At this point an X-ray crystallographic investigation of delcosine hydrobromide was started. Although this study is not yet quite completed, it is sufficiently advanced³⁵ to have yielded the crucial information which, however, can be considered at present as a good approximation only.

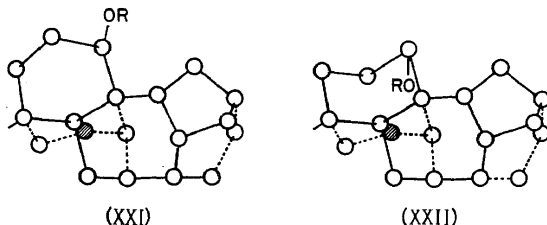

The carbon-nitrogen skeleton of delcosine (XXII) is indeed the same as that of lycoctonine (XXI). All the substituents are oriented as in lycoctonine except the hydroxyl at C-1 which, as shown by the chemical evidence, is oriented towards the same side of ring A as the nitrogen. Ring A, however, has a boat conformation whereas in lycoctonine it possesses a chair form. Hydrogen bonding between the C-1 hydroxyl and the free electron pair on the nitrogen accounts satisfactorily for the boat form of ring A in delcosine.

In the course of the preparation of the derivative of delcosine required for the correlation, four of the asymmetric centres in the molecule were involved. Two of these were altered in the same way in the lycoctonine derivative through the pinacolic transformation, and need not be considered. The other two (which are carbons 1 and 10 carrying the two secondary hydroxyls in delcosine) were involved in the one derivative but not in the other. It was now apparent that the differences noted between the two products must be attributable to one of these two asymmetric centres or to both.

It has now been established that the elaborate reactions meant to epimerize the C-1 hydroxyl simply gave back the original epimer. These reactions, however, also involved the oxidation of the C-10 hydroxyl to a carbonyl, and it is the reduction of this carbonyl with sodium borohydride that gave rise to the opposite epimer. Consequently, the epidelcosine used was not the epi-1-delcosine, but the epi-10-delcosine which accounts for the failure of the correlation.

The structures of both delcosine and delsoline, however, are now established. It is evident, in conclusion, that although conformational differences in some of the rings are possible, the lycoctonine carbon-nitrogen skeleton is common to all the highly-oxygenated diterpenoid alkaloids that have been investigated.

If on the one hand the ring structure of delpheline, deltaline and elatine in which an α -glycol system is methylenated has not been established rigorously—it is the structure of the demethylenated bases that is known unambiguously—yet, on the other hand, the argument that has led to the

HIGHLY-OXYGENATED DITERPENOID ALKALOIDS

suggestion of a different carbon–nitrogen skeleton for these bases is not at all compelling.

Finally, for the part of this work done at the National Research Council, Ottawa, I should like to acknowledge the contributions of O. E. Edwards and Maria Przybylska; also of Hans Mayer, D. J. McCaldin, Vinko Skarić, Zarko Stojanac, Robert Gilman, G. A. Mair and J. D. Connolly.

References

- ¹ R. C. Cookson, J. E. Page, and M. E. Trevett. *J. Chem. Soc.* **1954**, 4028.
- ² O. E. Edwards and L. Marion. *Can. J. Chem.* **30**, 627 (1952); **32**, 195 (1954); **32**, 1146 (1954);
O. E. Edwards, L. Marion, and D. K. R. Stewart. *Can. J. Chem.* **34**, 1315 (1956).
- ³ M. Przybylska and L. Marion. *Can. J. Chem.* **34**, 185 (1956).
- ⁴ O. E. Edwards, L. Marion, and R. A. McIvor. *Can. J. Chem.* **32**, 708 (1954).
- ⁵ O. E. Edwards, L. Marion, and K. H. Palmer. *J. Org. Chem.* **22**, 1372 (1957).
- ⁶ O. E. Edwards, M. Los, and L. Marion. *Proc. Chem. Soc.* **1959**, 192; *Can. J. Chem.* **37**, 1996 (1959).
- ⁷ M. Przybylska and L. Marion. *Can. J. Chem.* **37**, 1843 (1959).
- ⁸ R. C. Cookson and M. E. Trevett. *J. Chem. Soc.* **1956**, 3121.
- ⁹ M. Carmack, J. P. Ferris, J. Harvey, P. L. Magat, E. W. Martin, and D. W. Mayo. *J. Am. Chem. Soc.* **80**, 497 (1958).
- ¹⁰ O. E. Edwards, L. Marion, and K. H. Palmer. *Can. J. Chem.* **36**, 1097 (1958).
- ¹¹ M. Carmack, D. W. Mayo, and J. P. Ferris. *J. Am. Chem. Soc.* **81**, 4110 (1959).
- ¹² D. H. R. Barton and J. D. Cox. *J. Chem. Soc.* **1949**, 214.
- ¹³ A. D. Kusowkow. *J. Gen. Chem. (U.S.S.R.)* **25**, 422 (1955).
- ¹⁴ W. A. Jacobs and S. W. Pelletier. *J. Am. Chem. Soc.* **76**, 161 (1954).
- ¹⁵ K. Wiesner, F. Bickelhaupt, and Z. Valenta. *Tetrahedron* **4**, 418 (1958).
- ¹⁶ K. Wiesner, F. Bickelhaupt, D. R. Babin, and M. Götz. *Tetrahedron Letters* **3**, 11 (1959).
- ¹⁷ W. Schneider. *Naturwiss.* **44**, 492 (1957).
- ¹⁸ D. J. McCaldin and L. Marion. *Can. J. Chem.* **37**, 1071 (1959).
- ¹⁹ H. Mayer and L. Marion. *Can. J. Chem.* **37**, 856 (1959).
- ²⁰ M. Przybylska and L. Marion. *Can. J. Chem.* **37**, 1116 (1959).
- ²¹ K. Wiesner, M. Götz, D. L. Simmons, R. L. Fowler, F. W. Bachelor, R. F. C. Brown, and G. Büchi. *Tetrahedron Letters* **2**, 15 (1959).
- ²² F. W. Bachelor, R. F. C. Brown and G. Büchi. *Tetrahedron Letters* **10**, 1 (1959).
- ²³ K. Wiesner, D. L. Simmons, and R. L. Fowler. *Tetrahedron Letters* **18**, 1 (1959).
- ²⁴ W. A. Jacobs and S. W. Pelletier. *Chem. & Ind. (London)* **1960**, 591.
- ²⁵ R. B. Turner, J. P. Jeschke, and M. S. Gibson. *J. Am. Chem. Soc.* **82**, 5182 (1960).
- ²⁶ T. A. Henry and T. M. Sharp. *J. Chem. Soc.* **1928**, 1105.
- ²⁷ R. E. Gilman and L. Marion. *Tetrahedron Letters* **20**, 923 (1962).
- ²⁸ R. Majima and S. Morio. *Ber.* **57**, 1472 (1924).
- ²⁹ K. Wiesner, H. W. Brewer, D. L. Simmons, D. R. Babin, F. Bickelhaupt, J. Kallos, and T. Bogri. *Tetrahedron Letters* **3**, 17 (1960).
- ³⁰ V. Skarić and L. Marion. *Can. J. Chem.* **38**, 2433 (1960).
- ³¹ F. Sparatore, R. Greenhalgh, and L. Marion. *Tetrahedron* **4**, 157 (1958).
- ³² R. Anet, D. W. Clayton, and L. Marion. *Can. J. Chem.* **35**, 397 (1957).
- ³³ V. Skarić and L. Marion. *J. Am. Chem. Soc.* **80**, 4434 (1958).
- ³⁴ R. Anet and L. Marion. *Can. J. Chem.* **36**, 766 (1958).
- ³⁵ G. A. Mair and M. Przybylska. Unpublished results.
- ³⁶ V. Skarić and L. Marion. *Can. J. Chem.* **39**, 1579 (1961).